

ITEM	PART. No	DESCRIPTION.	QT. Y
1	C-66-1000000	USER MANUAL	1
2	H-20-1000000	LC320A. 00. 00	1

REVISION 13A-01

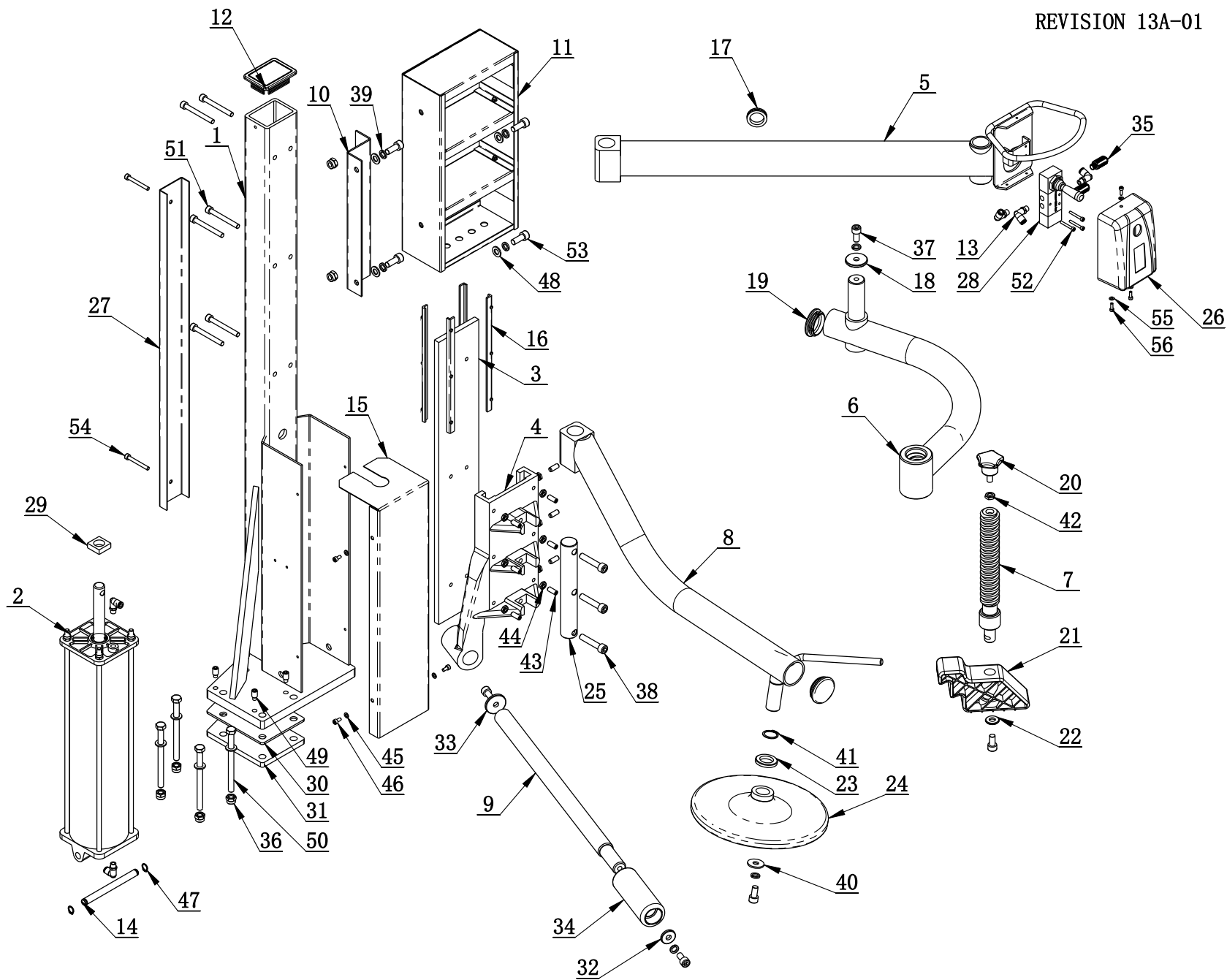

H-20-1000000

ITEM	PART. No	DESCRIPTION.	QT. Y
1	H-30-1300000	MAIN BODY BRACKET	1
2	H-10-1500000	LIFTING CYLINDER ASSEMBLY	1
3	H-10-1000004	GUIDE RAIL	1
4	H-30-1000001	MOBILE CARRIAGE	1
5	H-20-1100000	SUPPORT ARM	1
6	H-20-1200000	ROTATION ARM	1
7	H-20-1000001	PRESSURE SCREW	1
8	H-30-1200000	BEAD LIFTING ARM	1
9	H-30-1000005	MOVABLE SHAFT	1
10	H-10-1000015	FIXTURE PLATE	1
11	H-10-1900000	TOOL BOX ASSY	1
12	H-10-1000003	PROTECTIVE COVER	1
13	FPL 6-01	MALE ELBOW	5
14	H-10-1000018	SUPPORTING SHAFT	1
15	H-10-1000012	CYLINDER COVER PLATE	1
16	H-10-1000016	GUIDEWAY	4
17	H-12-0000002	PROTECTION RING	1
18	H-10-1000005	WASHER	1
19	H-10-1000008	ROUND COVER	2
20	JB3717. 22-85 M10-20	THE STAR HANDLE M10-20	1
21	H-10-1000006	PRESS BLOCK	1
22	H-10-1000007	PRESS WASHER	1
23	H-10-1000017	WASHER	1
24	H-10-1000011	TURNTABLE	1
25	H-10-1000002	SHAFT CONNECTOR	1
26	H-10-1000020	HANDLE VALVE COVER	1
27	H-10-1000013	U-STEEL	1
28	4H230-06A	CONTROL VALVE	1
29	H-12-1000001	FELT WASHER	1
30	H-30-1000008	PAD PLATE	1
31	H-30-1000007	BOTTOM FLAT PLATE	1
32	H-30-1000004	CONE ROLLER WASHER	1
33	H-30-1000006	WASHER	1
34	H-30-1000003	TIRE PRESSING ROLLER	1
35	FSK 01	PLASTIC PARTICLE SILENCER	2
36	GB889. 1-M10	1-TYPE PREVAILING TORQUE TYPE HEXAGON LOCK NUT	6
37	GB70. 1-M10×20	INNER HEXA CYLINDRICAL SCREW	5
38	GB70. 1-M10×50	INNER HEXA CYLINDRICAL SCREW	3
39	GB93-10	STANDARD SPRING WASHER	7
40	GB96. 1-10	LARGE WASHER A GRADE	1

ITEM	PART. No	DESCRIPTION.	QT. Y
41	GB894. 2-25	SHAFT ELATIC RETAINING RING B-TYPE	1
42	GB6172. 1-M10	HEXANGULAR THIN NUT	1
43	GB77-M8×20	INNER HEXA FLAT TERMINUS SET SCREW	9
44	GB6172. 1-M8	HEXANGULAR THIN NUT	9
45	GB95-5	FLAT WASHER	4
46	GB70. 1-M5×10	INNER HEXA CYLINDRICAL SCREW	4
47	GB894. 1-12	SHAFT ELATIC BIG RETAINING RING A-TYPE	2
48	GB95-10	FLAT WASHER	8
49	GB79-M10×20	INNER HEXA CYLINDRICAL TERMINUS SET SCREW	4
50	GB5782-M10×130	HEXANGULAR BOLT	4
51	GB70. 1-M8×70	INNER HEXA CYLINDRICAL SCREW	5
52	GB70. 1-M4×30	INNER HEXA CYLINDRICAL SCREW	3
53	GB70. 1-M10×25	INNER HEXA CYLINDRICAL SCREW	4
54	GB70. 1-M6×50	INNER HEXA CYLINDRICAL SCREW	2
55	GB95-4	FLAT WASHER	3
56	GB5781- M4×12	INNER HEXA CYLINDRICAL SCREW	3

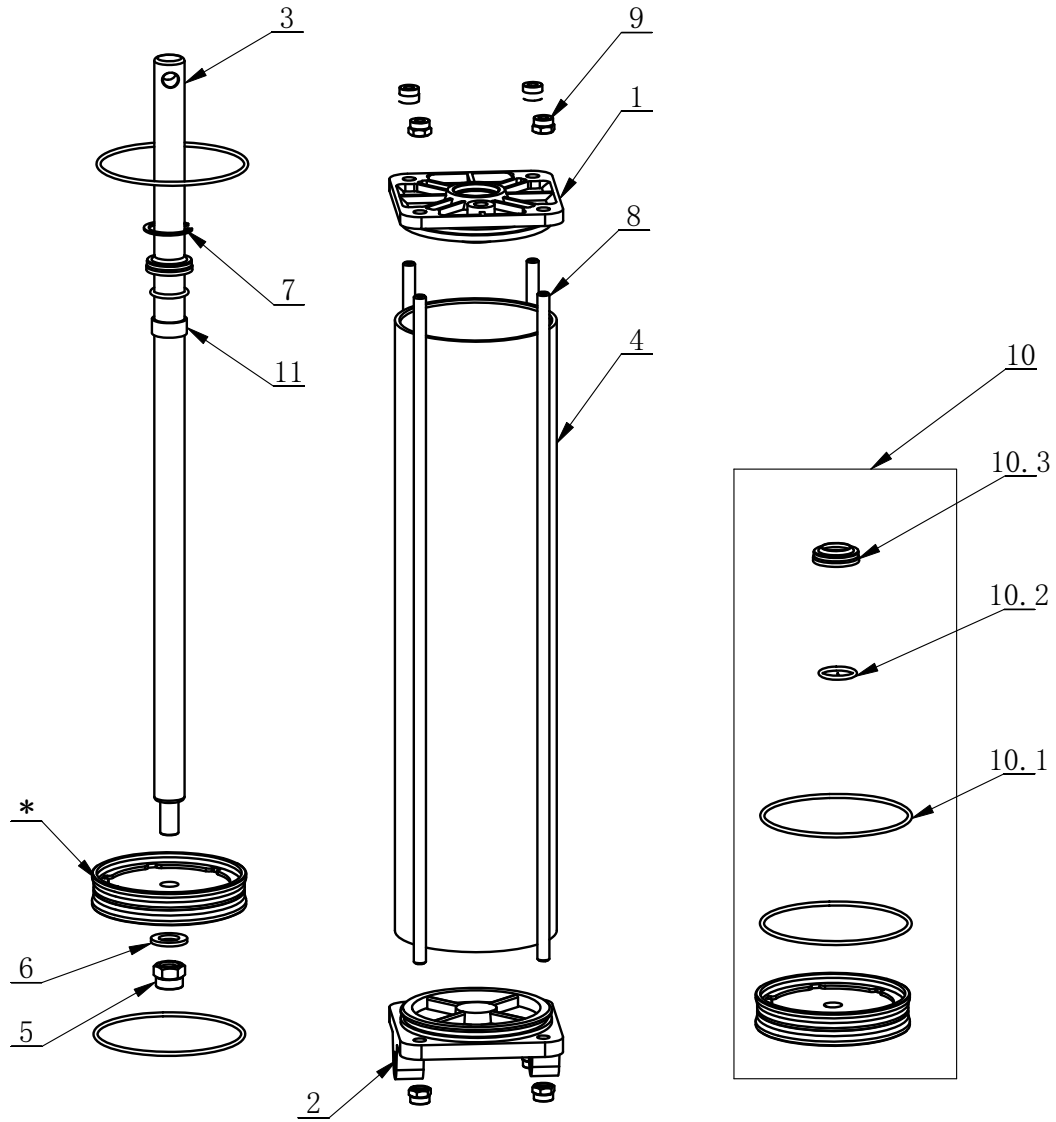

ITEM	PART. No	DESCRIPTION.	QT. Y
1	H-10-1500002	CYLINDER FRONT COVER	1
2	H-10-1500005	CYLINDER BEAR COVER	1
3	H-10-1500004	PISTON ROD	1
4	H-10-1500003	CYLINDER	1
5	GB889. 1-M12	1- TYPE PREVAILING TORQUE TYPE HEXAGON LOCK NUT	1
6	GB95-12	FLAT WASHER	1
7	GB893. 1-30	ELASTIC RETAINING RING A-TYPE	1
8	H-10-1500006	BOLT	4
9	GB889. 1-M8	1-TYPE PREVAILING TORQUE TYPE HEXAGON LOCK NUT	8
10	H-10-1510000	CYCLINDER SEALING OARTS ASSEMBLY	1
10. 1	GB3452. 1-95×2. 65-G	HYDRAULIC-PNEUMATIC RUBBER O-RING G TYPE	2
10. 2	GB3452. 1-20×2. 65	HYDRAULIC-PNEUMATIC RUBBER O-RING G TYPE	1
10. 3	BYXQ30x20x7	SEAL-ROD, CYLNDR	1
10. 4	H-10-1500001	PISTON	1
11	JH1 2010	BEARING-SLIDE	1

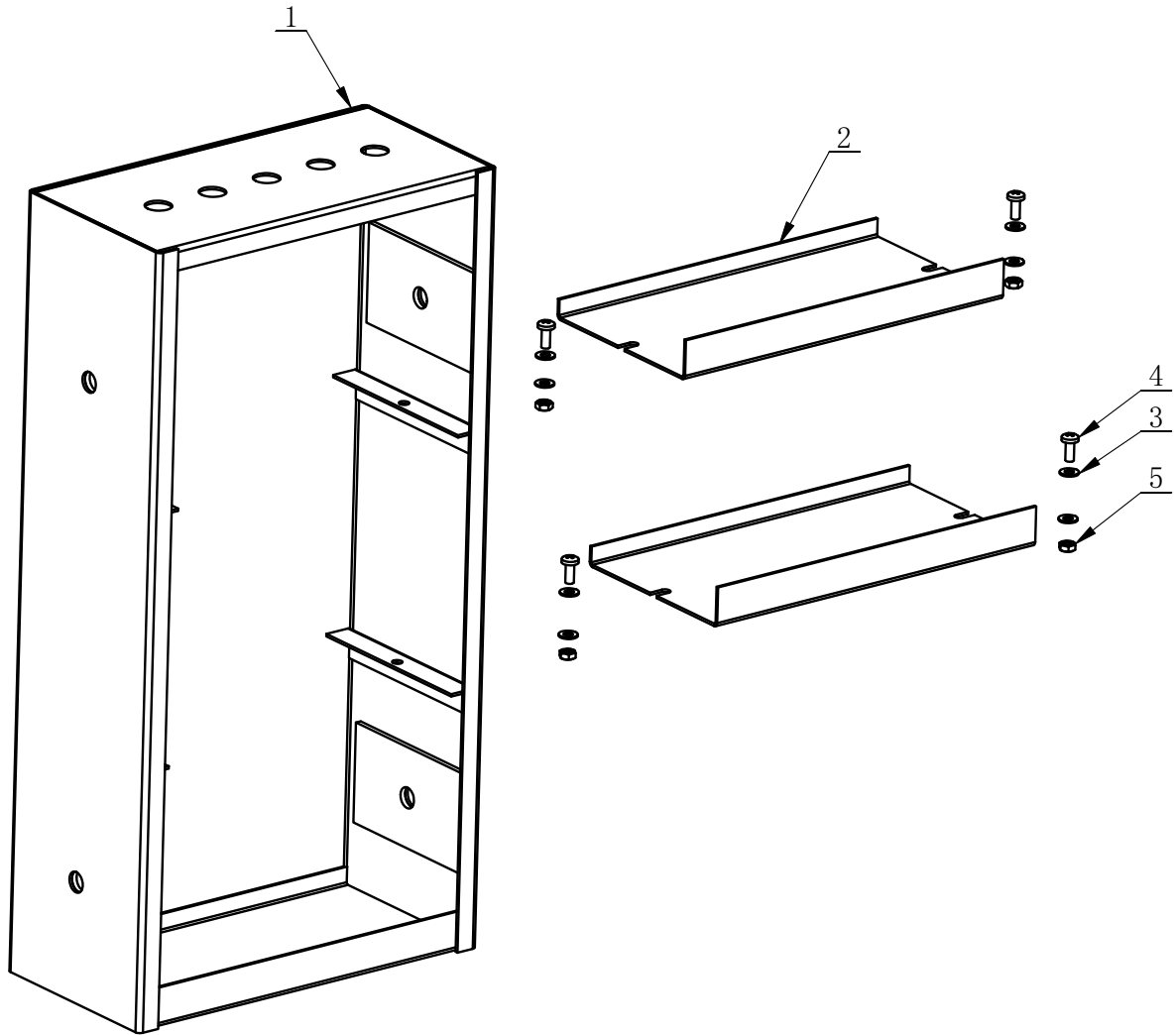

ITEM	PART. No	DESCRIPTION.	QT. Y
1	H-10-1910000	TOOL BOX ASSY WELDING	1
2	H-10-1900002	SPACE	2
3	GB95-4	FLAT WASHER	8
4	GB818-M4×10-H	CROSS PANHEAD SCREW	4
5	GB6170-M4	HEXANGULAR NUT 1-TYPE	4

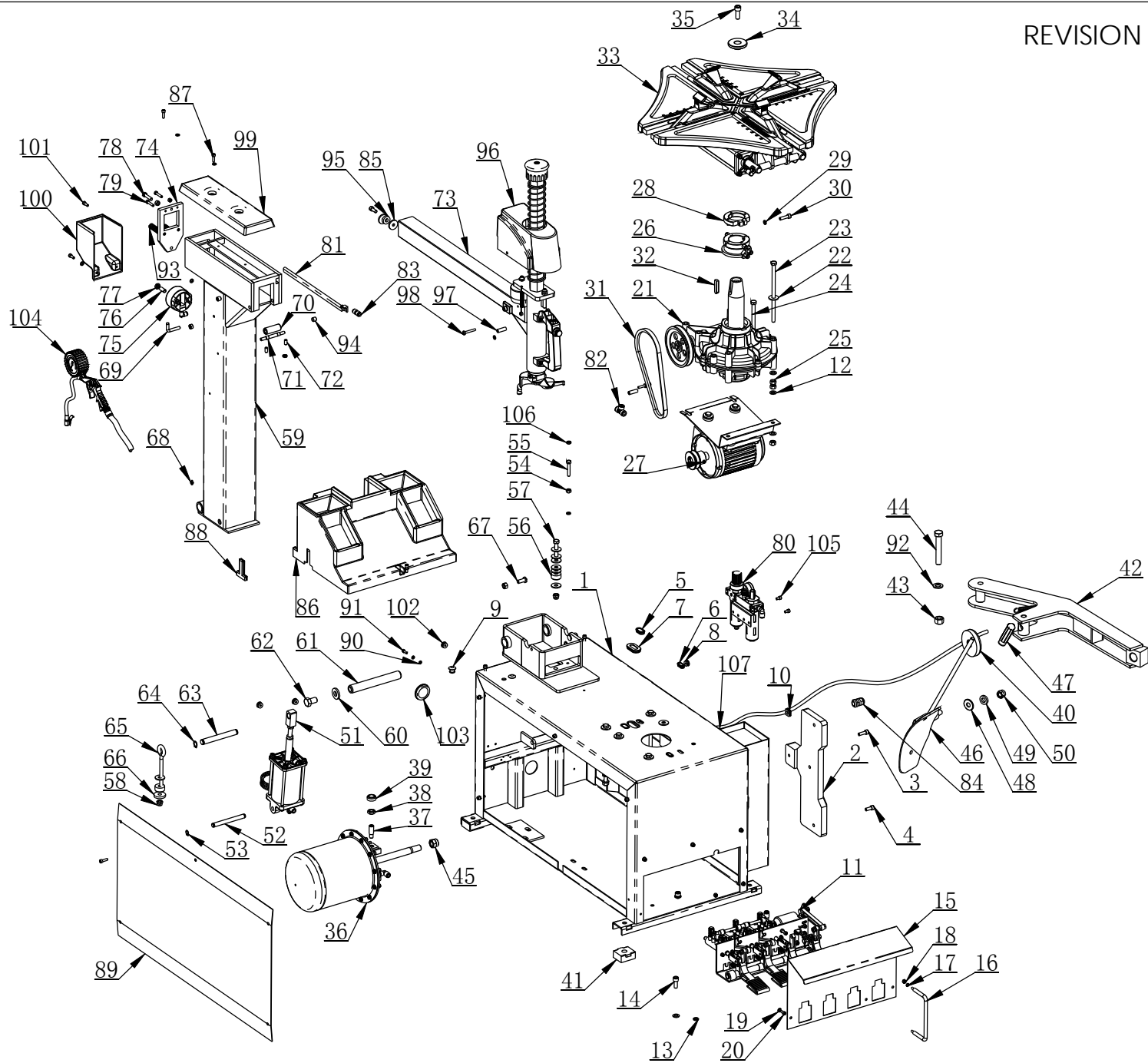

ITEM	PART. No	DESCRIPTION.	QT. Y
1	C-71-1100000	BODY	1
2	C-54-1000006	RUBBER PAD PLATE	1
3	GB70. 1-M8×25	INNER HEXA CYLINDRICAL SCREW	1
4	GB70. 1-M8×20	INNER HEXA CYLINDRICAL SCREW	4
5	C-54-1000022	PLUG C	2
6	C-54-1000023	PLUG A	2
7	C-54-1000028	PLUG B	1
8	C-71-1000027	HELPER RUBBE PLUG	3
9	C-71-1000020	STOP-UP	2
10	C-54-1000015	STOP-UP	1
11	CT-D-4200000	PEDAL ASSEMBLY	1
12	GB95-10	FLAT WASHER	16
13	GB93-10	STANDARD SPRING WASHER	2
14	GB70. 1-M10×25	INNER HEXA CYLINDRICAL SCREW	2
15	C-71-1000004	PROTECTIVE COVER	1
16	C-71-1000005	PROTECTIVE ROD	1
17	GB93-6	STANDARD SPRING WASHER	2
18	GB41-M6	HEXANGULAR NUT	4
19	GB95-6	FLAT WASHER	19
20	GB70. 1-M6×12	INNER HEXA CYLINDRICAL SCREW	5
21	CT-J-3100000	GEARBOX ASSEMBLY	1
22	GB96. 2-10	LARGE WASHER C GRADE	13
23	GB5782-M10×200-W8. 8	HEXANGULAR BOLT	4
24	GB5782-M10×160-W8. 8	HEXANGULAR BOLT	2
25	GB41-M10	HEXANGULAR NUT	16
26	CT-Q-1000000	ROTATING UNION	1
27	CT-DJ-0334122	MOTOR H	1
28	CT-Q-6000000	CLAMP RING	1
29	GB93-8	STANDARD SPRING WASHER	3
30	GB70. 1-M8×30	INNER HEXA CYLINDRICAL SCREW	1
31	CT-DJ-0000007	BELT	1
32	GB1096-C12×8×45	COMMON FLAT KEY	1
33	CT-Y-1A00000	TURNTABLE ASSEMBLY	1
34	C-54-1000012	PRESS COVER	1
35	GB70. 1-M12×30	INNER HEXA CYLINDRICAL SCREW	1
36	CT-LS-2600000	BEAD BREAKER CYLINDER ASSEMBLY	1
37	C-54-1000010	SCREWS M14X42	2
38	GB6172. 1-M14	HEXANGULAR THIN NUT	2
39	C-54-1000013	SEALED COVER	1
40	C-54-1000016	RUBBER WASHER	1

ITEM	PART. No	DESCRIPTION.	QT. Y
41	C-54-1000005	RUBBER FOOT	4
42	CT-B-2000000	BEAD BREAKER	1
43	GB41-M16	HEXANGULAR NUT	1
44	GB5782-M16×100	HEXANGULAR BOLT	1
45	GB889. 2-M18×1. 5	NUT M18X1. 5	1
46	CT-C-2100000	BEAD BREAKER BLADE	1
47	TC-40-1200022	RUBBER COVER	1
48	C-54-1000002	WASHER	1
49	GB955-14	WAVE-FORM SPRING WASHER	1
50	GB889. 1-M14	1-TYPE PREVAILING TORQUE TYPE HEXAGON LOCK NUT	1
51	CT-XD-3000000	PULL-OUT CYLINDER D80X80	1
52	C-71-1000006	PIN SHAFT	1
53	GB894. 1-12	SHAFT ELATIC BIG RETAINING RING A-TYPE	2
54	GB41-M8	HEXANGULAR NUT	4
55	GB5782-M8×45	HEXANGULAR BOLT	2
56	C-71-1000013	WASHER Φ30xΦ10x15	2
57	GB5782-M10×50	HEXANGULAR BOLT	1
58	GB889. 1-M10	1-TYPE PREVAILING TORQUE TYPE HEXAGON LOCK NUT	2
59	C-77-1200000	COLUMN WELDING DRAWING	1
60	C-71-1000010	WASHER	2
61	C-71-1000012	ROTATION SHAFT	1
62	GB5782-M16×25-W8. 8	HEXANGULAR BOLT	2
63	C-71-1000007	PULL-OUT SHAFT	1
64	GB894. 1-16	SHAFT ELATIC BIG RETAINING RING A-TYPE	2
65	C-71-1000008	CONNECTION ROD	1
66	C-71-1000028	WASHER	1
67	C-71-1000009	BOLT	2
68	TC-10-8400006	OIL CUP M6	1
69	C-71-1000024	INFLATING GUN HOOK	1
70	C-77-1000001	ROTATING SPACER	1
71	C-77-1000002	SUPPORT SHAFT	1
72	GB77-M8×16	INNER HEXA FLAT TERMINUS SET SCREW	2
73	C-77-1300000	HORIZONTAL ARM ASSEMBLY	1
74	C-77-1400000	QUADRIC LOCK PLATE WELDING	1
75	C-77-1500000	LOCKING CYLINDER ASSY	1
76	C-71-1000029	INNER HEXA FLAT TERMINUS SET SCREW	1
77	GB6173-M10×1. 0	HEXA THIN NUT	1
78	GB5781-M8×35	HEXANGULAR BOLT	1
79	GB5782-M6×30	HEXANGULAR BOLT	2
80	CT-F-2111200	AIR REGULATOR ASSEMBLY	1

ITEM	PART. No	DESCRIPTION.	QT. Y
81	C-77-1000009	AIR HOSE CHUTE	1
82	FPT 6-8-8	DIFFERENT DIA OF UNION TEE	1
83	FPU-6	UNION STRAIGHT	1
84	C-54-1000017	CABLE CONNECTOR	1
85	C-77-1000003	CUSHION	2
86	C-71-1000025	PROTECTIVE COVER	1
87	GB70. 1-M6×20	INNER HEXA CYLINDRICAL SCREW	10
88	C-54-1000020	T-PLUG	1
89	C-61-1000001	SIDE PANEL	1
90	GB95-5	FLAT WASHER	2
91	GB5782-M5×16-8. 8	HEXANGULAR BOLT	1
92	GB95-16	WASHER	1
93	C-71-1000018	PRESS SPRING	2
94	GB77-M12×12	INNER HEXA FLAT TERMINUS SET SCREW	2
95	C-77-1000004	RUBBER WASHER	1
96	C-80-1000007	PROTECTION COVER	1
97	C-77-1000006	PROTECTIVE HOOD LOCK BUSHING	2
98	GB818-M6×40-H	CROSS PANHEAD SCREW	2
99	C-77-1000007	PROTECTIVE COVER	1
100	C-77-1000008	PROTECTIVE COVER	1
101	GB70. 1-M6×16	INNER HEXA CYLINDRICAL SCREW	2
102	C-61-1000003	HELPER RUBBE PLUG	1
103	C-61-1000002	CUSHION BUSHING	1
104	CT-P-1000000	INFLATING GUN ASSY	1
105	GB70. 1-M6×10	INNER HEXA CYLINDRICAL SCREW	2
106	GB6172. 1-M8	HEXANGULAR THIN NUT	2
107A	C-54-1000030	380V CABLE	1
107B	C-54-1000040	220V CABLE	1

C-77-1300000

REVISION 13A-01

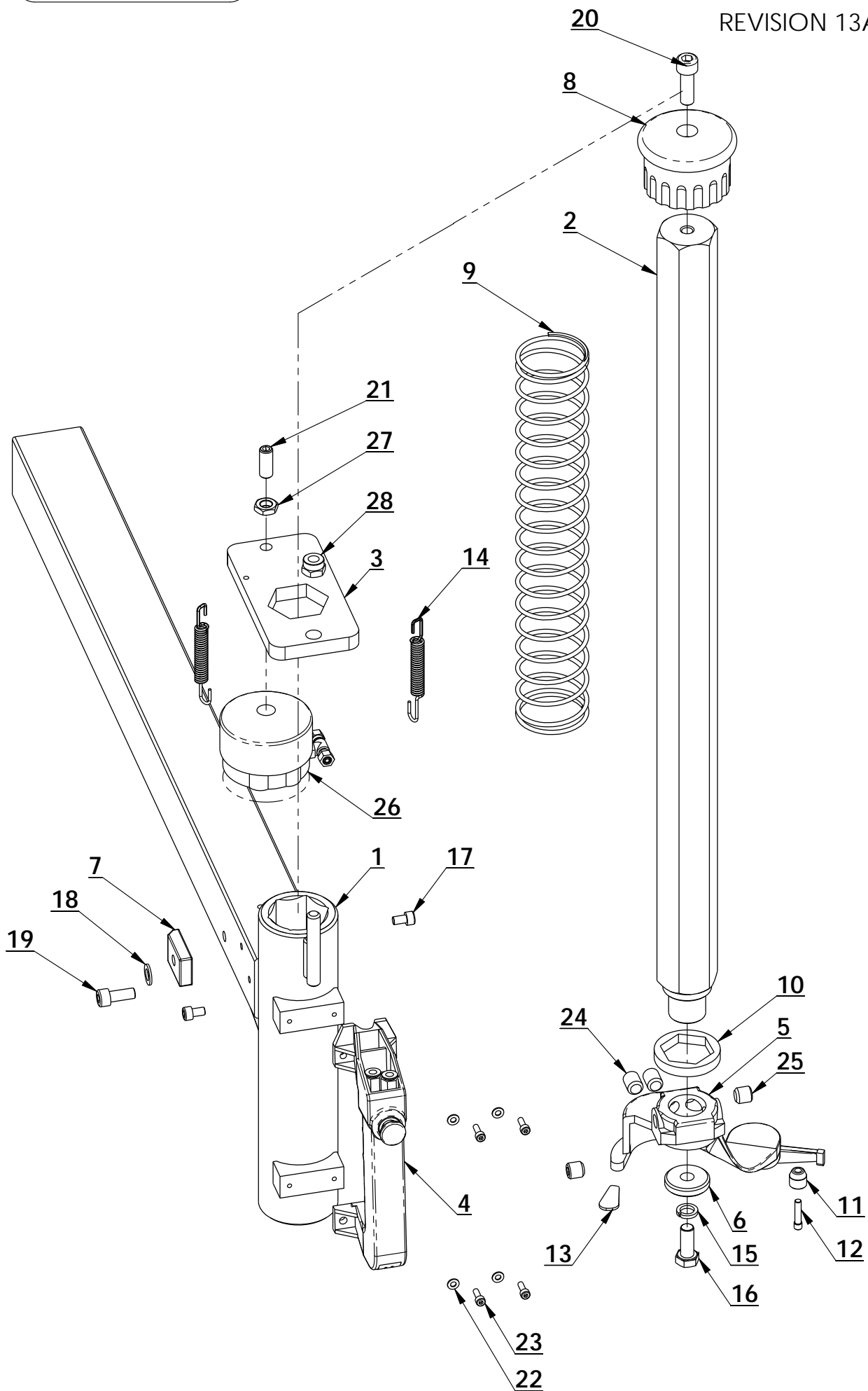

ITEM	PART. No	DESCRIPTION.	QT. Y
1	C-77-1310000	HORIZONTAL ARM WELDING	1
2	C-77-1300003	HEXANGULAR SHAFT	1
3	C-77-1300004	HEXANGULAR LOCK PLATE	1
4	C-71-1330000	HANDLE CONTROLING VALVE	1
5	C-54-1300004	DEMOUNTING HEAD	1
6	C-54-1300008	PRESS WASHER	1
7	C-71-1300005	POSITIONING BLOCK	1
8	C-54-1300003	VERTICAL SHAFT COVER	1
9	C-54-1300010	VERTICAL SHAFT SPRING	1
10	C-54-1300007	SHOCK ABSORBER WASHER	1
11	C-54-1300009	ROLLER	1
12	C-54-1300006	ROLLER BOLT	1
13	C-54-8000007	PLASTIC COVER	1
14	C-71-1300004	SPRING	2
15	GB93-10	STANDARD SPRING WASHER	1
16	GB5783-M10×25-W8.8	HEXANGULAR BOLT	1
17	GB70.1-M6×10	INNER HEXA CYLINDRICAL SCREW	2
18	GB95-8	FLAT WASHER	1
19	GB70.1-M8×20	INNER HEXA CYLINDRICAL SCREW	1
20	GB70.1-M10×30	INNER HEXA CYLINDRICAL SCREW	1
21	C-71-1000029	INNER HEXA FLAT TERMINUS SET SCREW	1
22	GB95-4	FLAT WASHER	4
23	GB5781- M4×12	INNER HEXA CYLINDRICAL SCREW	4
24	GB77-M12×16	INNER HEXA FLAT TERMINUS SET SCREW	2
25	GB77-M12×12	INNER HEXA FLAT TERMINUS SET SCREW	2
26	C-71-1320000	LOCKING CYLINDER ASSY	1
27	GB6173-M10×1.0	HEXA THIN NUT	1
28	GB889.1-M10	1-TYPE PREVAILING TORQUE TYPE HEXAGON LOCK NUT	1

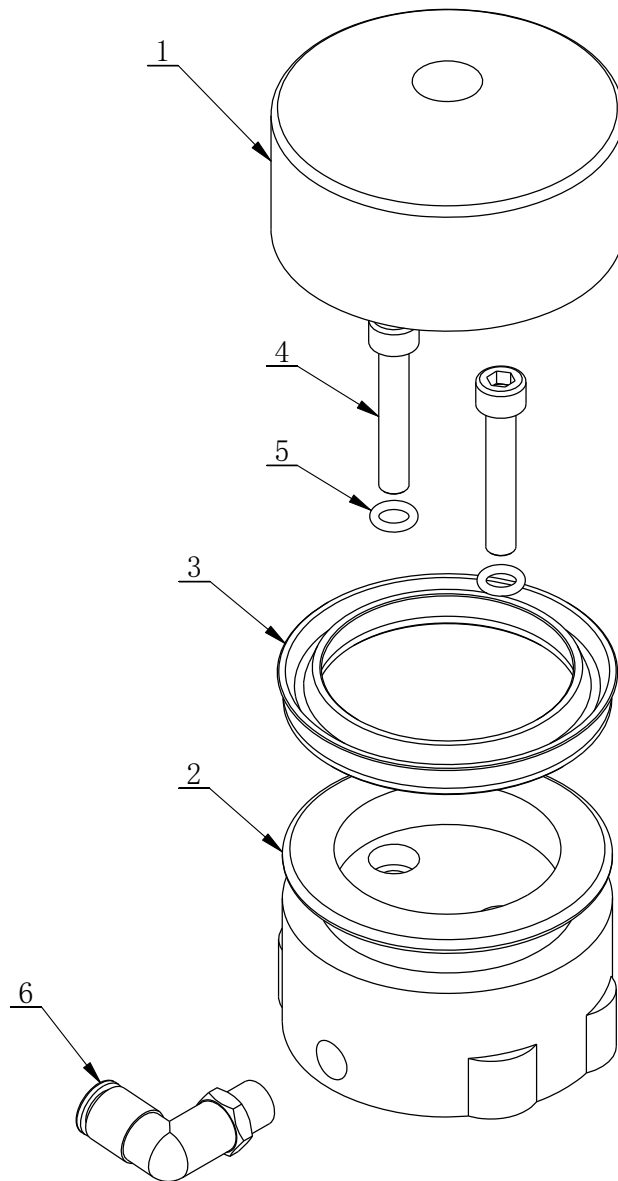

ITEM	PART. No	DESCRIPTION.	QT. Y
1	C-71-1320001	LOCK TURNTABLE CYLINDER HEAD	1
2	C-71-1320002	LOCK CYLINDER BODY	1
3	C-71-1320003	Y-RING	1
4	GB70. 1-M6×35	INNER HEXA CYLINDRICAL SCREW	2
5	GB3452. 1-6×1.8-G	HYDRAULIC-PNEUMATIC RUBBER O-RING G TYPE	1
6	FPL 6-01	MALE ELBOW	1

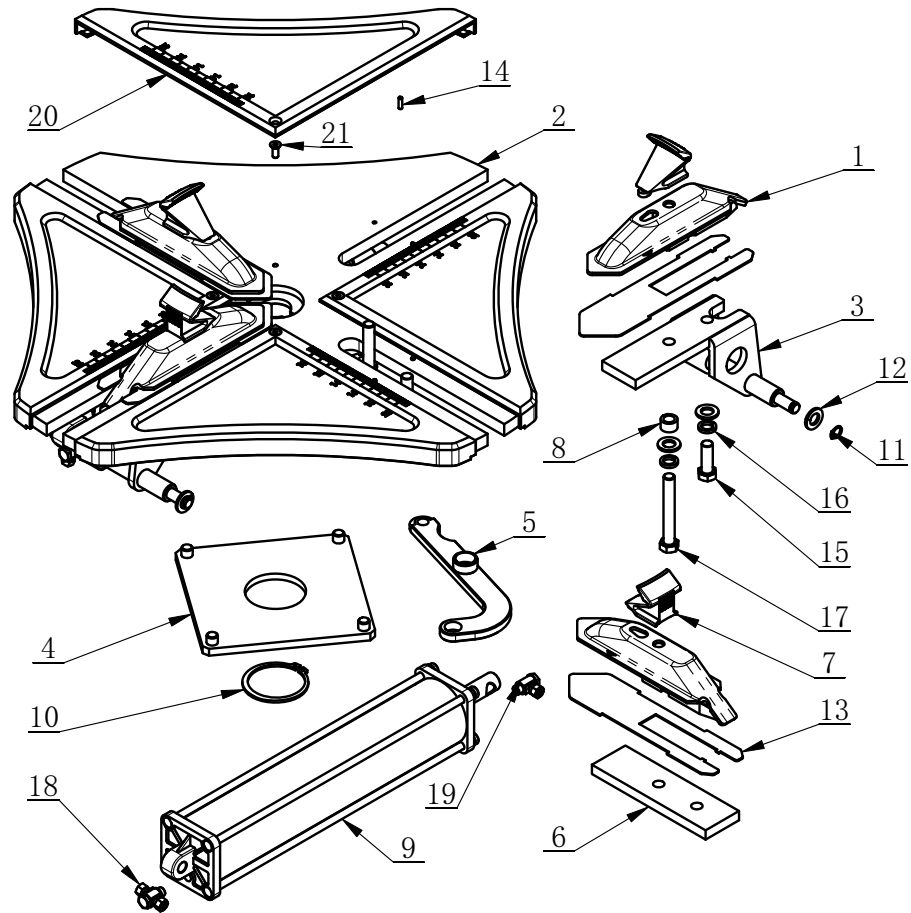

ITEM	PART. No	DESCRIPTION.	QT. Y
1	CT-Y-0710000	SLIDE COVER	4
2	CT-Y-1A10000	TURN TALBE	1
3	CT-Y-1140000	BRACKET-CYLINDER	2
4	CT-Y-0150000	SQUARE TURNTABLE	1
5	CT-Y-1150000	CONNECTION PLATE	4
6	CT-Y-1100001	PRESS BOARD	2
7	CT-Y-0100002	CLAMP	4
8	CT-Y-0100003	SPACER	4
9	CT-Y-1430000	CYLINDER ASSEMBLY	2
10	GB894. 1-65	SHAFT ELATIC BIG RETAINING RING A-TYPE	1
11	GB894. 1-12	SHAFT ELATIC BIG RETAINING RING A-TYPE	4
12	GB95-12	FLAT WASHER	12
13	CT-Y-1400001	WEAR-RESISTANCE SPACER	4
14	GB879. 1-4×14	ELASTIC CYLINDRICAL PIN HEAVY	8
15	GB5783-M12×35	HEXANGULAR BOLT	4
16	GB93-12	STANDARD SPRING WASHER	8
17	GB5782-M12×85	HEXANGULAR BOLT	4
18	CT-Y-0100009	HINGE ELBOW Φ6	2
19	CT-Y-0100007	HINGE ELBOW Φ6 R1/8"	2
20	CT-Y-1A00001	PROTECTIVE COVER	4
21	GB70. 3-M6×16	INNER COUNTER SUNK SCREW	4

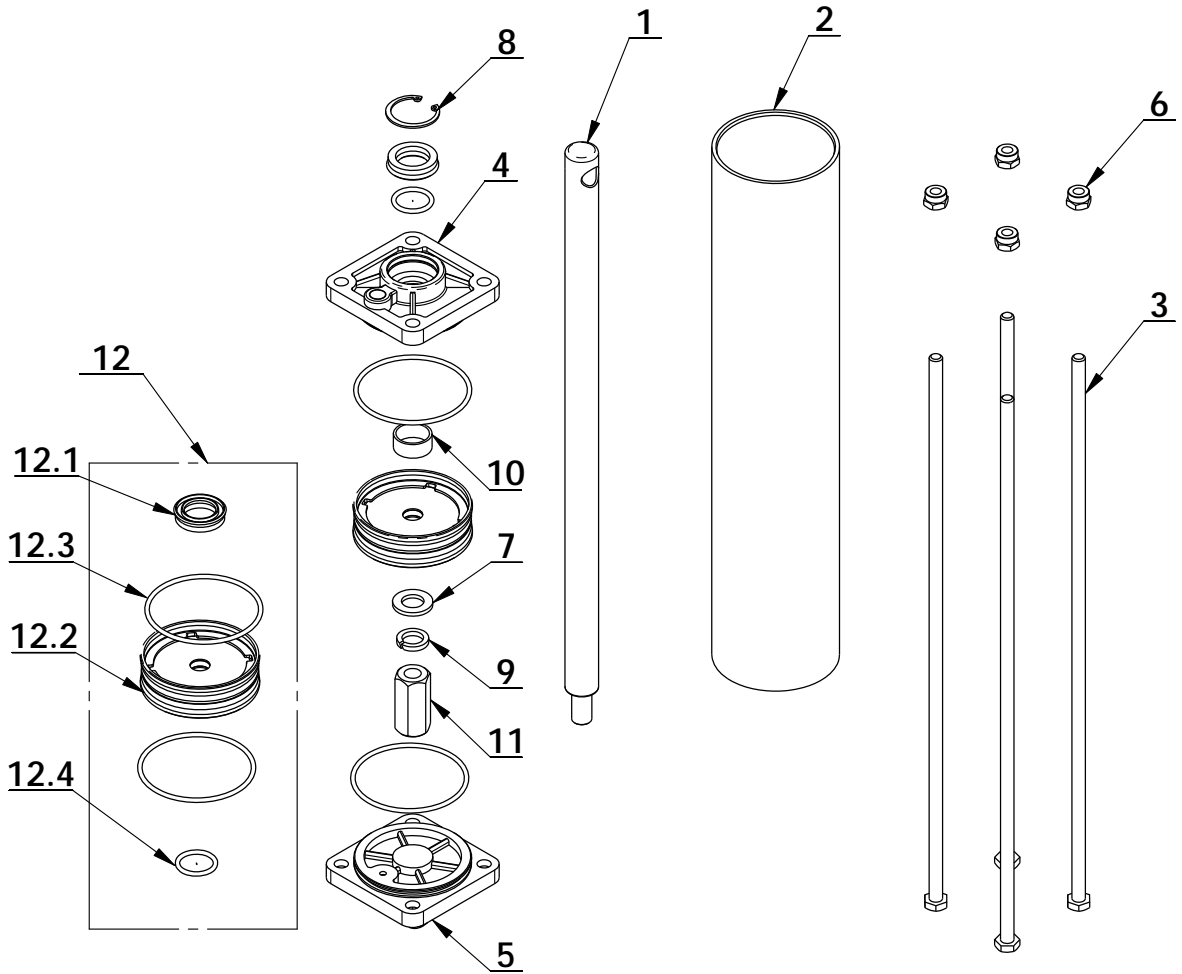

ITEM	PART. No	DESCRIPTION.	QT. Y
1	CT-Y-1120001	SHAFT-CYLNDR	1
2	CT-Y-1120002	SLEEVE-CYLNDR 70	1
3	CT-Y-1120003	BOLT	4
4	CT-Y-0160002	FRONT COVER	1
5	CT-Y-0160003	REAR COVER	1
6	GB889. 1-M8	1-TYPE PREVAILING TORQUE TYPE HEXAGON LOCK NUT M8	4
7	GB95-12	FLAT WASHER	1
8	GB893. 1-30	ELASTIC RETAINING RING A-TYPE	1
9	GB93-12	STANDARD SPRING WASHER	1
10	JH1 2010	BEARING-SLIDE	1
11	CT-Y-1430001	AN ELONGATED NUT	1
12	CT-Y-1121000	CYLINDER SEALING PARTS ASSEMBLY	1
12. 1	CT-Y-0160007	SEAL-ROD, CYLNDR	1
12. 2	CT-Y-0161000	PISTON-W/WSHR, ASSY	1
12. 3	GB3452. 1-65×2. 65	HYDRAULIC-PNEUMATIC RUBBER O-RING G TYPE	2
12. 4	GB3452. 1-20×2. 65	HYDRAULIC-PNEUMATIC RUBBER O-RING G TYPE	1

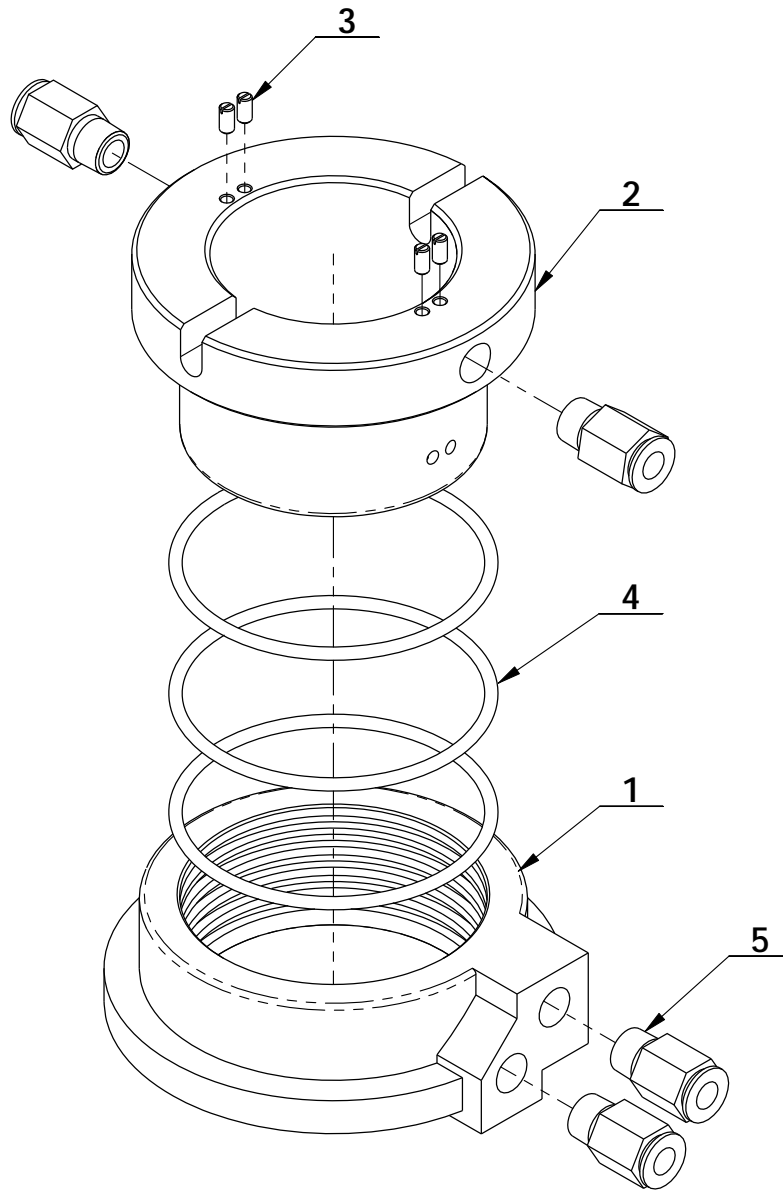

ITEM	PART. No	DESCRIPTION.	QT. Y
1	CT-Q-1000001	AIR GUIDE EXTERNAL BUSHING	1
2	CT-Q-1000002	AIR GUIDE ROTATION BUSHING	1
3	GB73-M3×6	SLOTTED FLATTEN HEAD SET SCREW	4
4	GB3452.1-60×2.65-G	HYDRAULIC-PNEUMATIC RUBBER O-RING G TYPE	3
5	FPC 6-01	MALE STRAIGHT	4

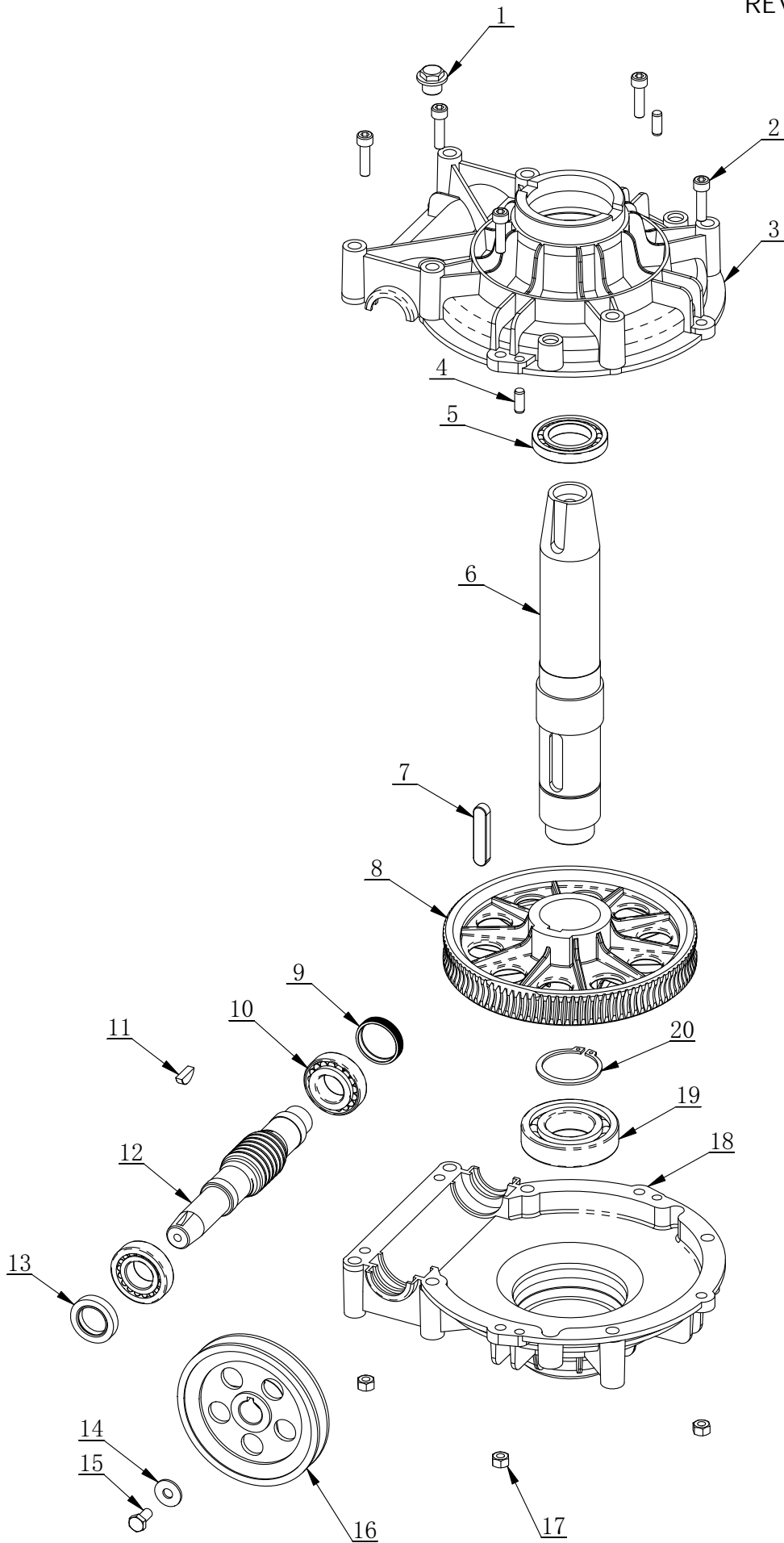

ITEM	PART NO.	DESCRIPTION	QTY
1	TC-10-1400013	BOLT	1
2	GB70. 1-M8×30	INNER HEXA CYLINDRICAL SCREW	5
3	CT-J-0000006	GEARBOX TOP	1
4	GB119. 1-8×20	CYLINDRICAL PIN	2
5	GB276-6010	DEEP GROOVE BALL BEARINGS	1
6	CT-J-0000001	WORM SHAFT	1
7	GB1096-12×8×56	COMMON FLAT KEY	1
8	CT-J-0000003	WORM	1
9	CT-J-0100000	CAP	1
10	GB297-30205	CYLINDRICAL BALL BEARING	2
11	GB1099. 1-6×9×22	COMMON SEMI-CIRCULAR KEY	1
12	CT-J-0000004	WORM ROD	1
13	FB25-40 GB13871. 92	SEALED RING	1
14	GB96. 2-8	LARGE WASHER C GRADE	1
15	GB5781-M8×16	HEXANGULAR BOLT	1
16	CT-J-0000008	BELT PULLEY	1
17	GB41-M8	HEXANGULAR NUT	5
18	CT-J-0000005	GEARBOX TOP	1
19	GB276-6208	DEEP GROOVE BALL BEARINGS	1
20	GB894. 1-50	SHAFT ELATIC BIG RETAINING RING A-TYPE	1

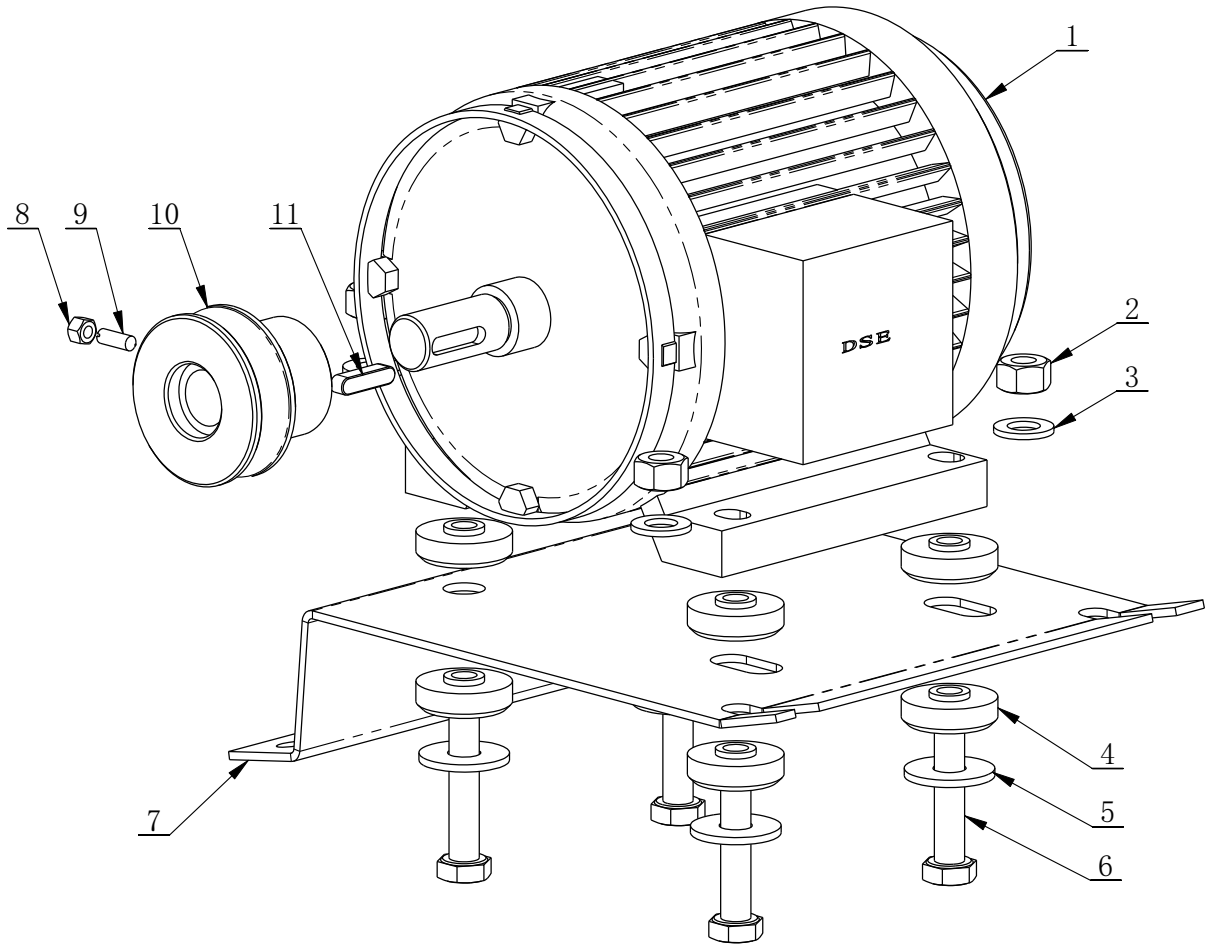

ITEM	PART. NO	DESCRIPTION	QT. Y
1A	CT-DJ-0034122	MOTOR(0.75KW 380V 50Hz 3P)	1
1B	CT-DJ-0018112	MOTOR(1.1KW 220~240V 50Hz 1P)	1
2	GB41-M10	HEXANGULAR NUT	4
3	GB95-10	FLAT WASHER	4
4	CT-DJ-0000002	RUBBER WASHER	8
5	GB96.2-10	LARGE WASHER C GRADE	4
6	GB5781-M10×50	HEXANGULAR BOLT	4
7	CT-DJ-0000001	MOTOR SUPPORT	1
8	GB41-M5	HEXANGULAR NUT	1
9	GB71-M5×16	SLOTTED CONIC HEAD SET SCREW	1
10A	CT-DJ-0000004	380V MOTOR BELT PULLEY (Φ58X46)	1
10B	CT-DJ-0000003	220V MOTOR BELT PULLEY (Φ58X40)	1
11	GB1096-6×6×25	COMMON FLAT KEY	1

REVISION 13A-01

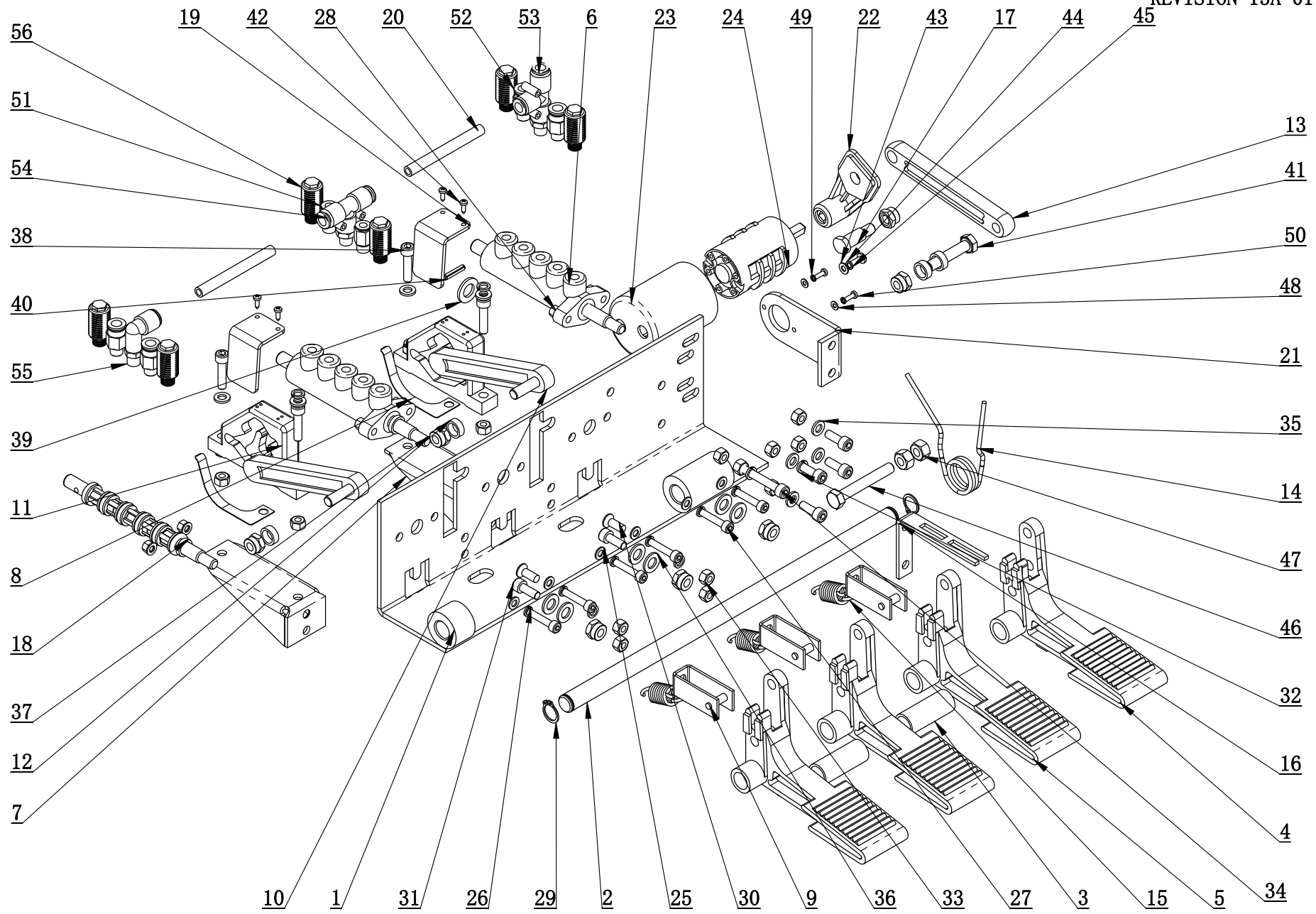

CT-D-4200000

ITEM	PART. No	DESCRIPTION.	QT. Y
1	CT-D-4110000	PEDAL SUPPORT WELDING	1
2	CT-D-4100001	BOTTOM SHAFT	1
3	CT-D-2100001	SPACER	2
4	CT-D-2100006	PEDAL	1
5	CT-D-2100007	PEDAL	3
6	CT-D-2140000	VALVE	3
7	CT-D-2120000	CAM BRACKET WELDING	2
8	CT-D-2100004	SPRING PLATE	2
9	CT-D-2130000	BRACKET RIVETING	3
10	CT-D-1100008	CAM CONNECTING ROD	2
11	CT-D-1100009	CAM	2
12	CT-D-2100005	SPACER	4
13	CT-D-2100011	CONNECTION ROD	1
14	CT-D-2100002	TORSION SPRING	1
15	CT-D-2100003	SPRING	3
16	CT-D-2100010	TORSION SPRING BRACKET	1
17	CT-D-2100012	ROTATION SHAFT	1
18	CT-D-1100016	SPACER	2
19	CT-D-1100011	CAM BAFFLE PLATE	2
20	CT-D-2100013	HOSE	2
21	CT-D-2200001	SWITCH SUPPORT	1
22	CT-D-1200002	REVERSE LEVER	1
23	CT-D-1200003	SWITCH COVER	1
24	CT-D-1200004	SWITCH	1
25	GB95-5	FLAT WASHER	12
26	GB93-5	STANDARD SPRING WASHER	6
27	GB70. 1-M5×25	INNER HEXA CYLINDRICAL SCREW	6
28	GB41-M5	HEXANGULAR NUT	6
29	GB894. 1-14	SHAFT ELATIC BIG RETAINING RING A-TYPE	2
30	GB819. 1-M6×16-H	CROSS COUNTERSUNK SCREW STEEL 4.8 GRADE	2
31	GB70. 1-M6×16	INNER HEXA CYLINDRICAL SCREW	6
32	GB93-6	STANDARD SPRING WASHER	11
33	GB41-M6	HEXANGULAR NUT	14
34	GB70. 1-M6×40	INNER HEXA CYLINDRICAL SCREW	1
35	GB95-6	FLAT WASHER	8
36	GB95-8	FLAT WASHER	6
37	GB889. 1-M8	I-TYPE PREVAILING TORQUE TYPE HEXAGON LOCK NUT M8	7
38	GB70. 1-M6×25	INNER HEXA CYLINDRICAL SCREW	4
39	GB95-10	FLAT WASHER	1

ITEM	PART. No	DESCRIPTION.	QT. Y
40	GB879. 1-4×20	ELASTIC CYLINDRICAL PIN, HEAVY	1
41	GB5781-M8×40	HEXANGULAR BOLT	1
42	GB845-ST2. 9×9. 5 H C	CROSS PANHEAD TAPPING SCREW	4
43	GB95-4	FLAT WASHER	1
44	GB93-4	STANDARD SPRING WASHER	1
45	GB818-M4×12-H	CROSS PANHEAD SCREW	1
46	GB5782-M8×55	HEXANGULAR BOLT	1
47	GB41-M8	HEXANGULAR NUT	2
48	GB95-3	FLAT WASHER	2
49	GB93-3	STANDARD SPRING WASHER	2
50	GB818-M3×10-H	CROSS PANHEAD SCREW	2
51	FPC 6-01	MALE STRAIGHT	2
52	FPC 8-01	MALE STRAIGHT	4
53	FPD 8-01	MALE RUN TEE	1
54	FPB 8-01	MALE BRANCH TEE	1
55	FPL 8-01	INSERT ELBOW Φ8, R1/8	1
56	FSK 01	PLASTIC PARTICLE SILENCER	6

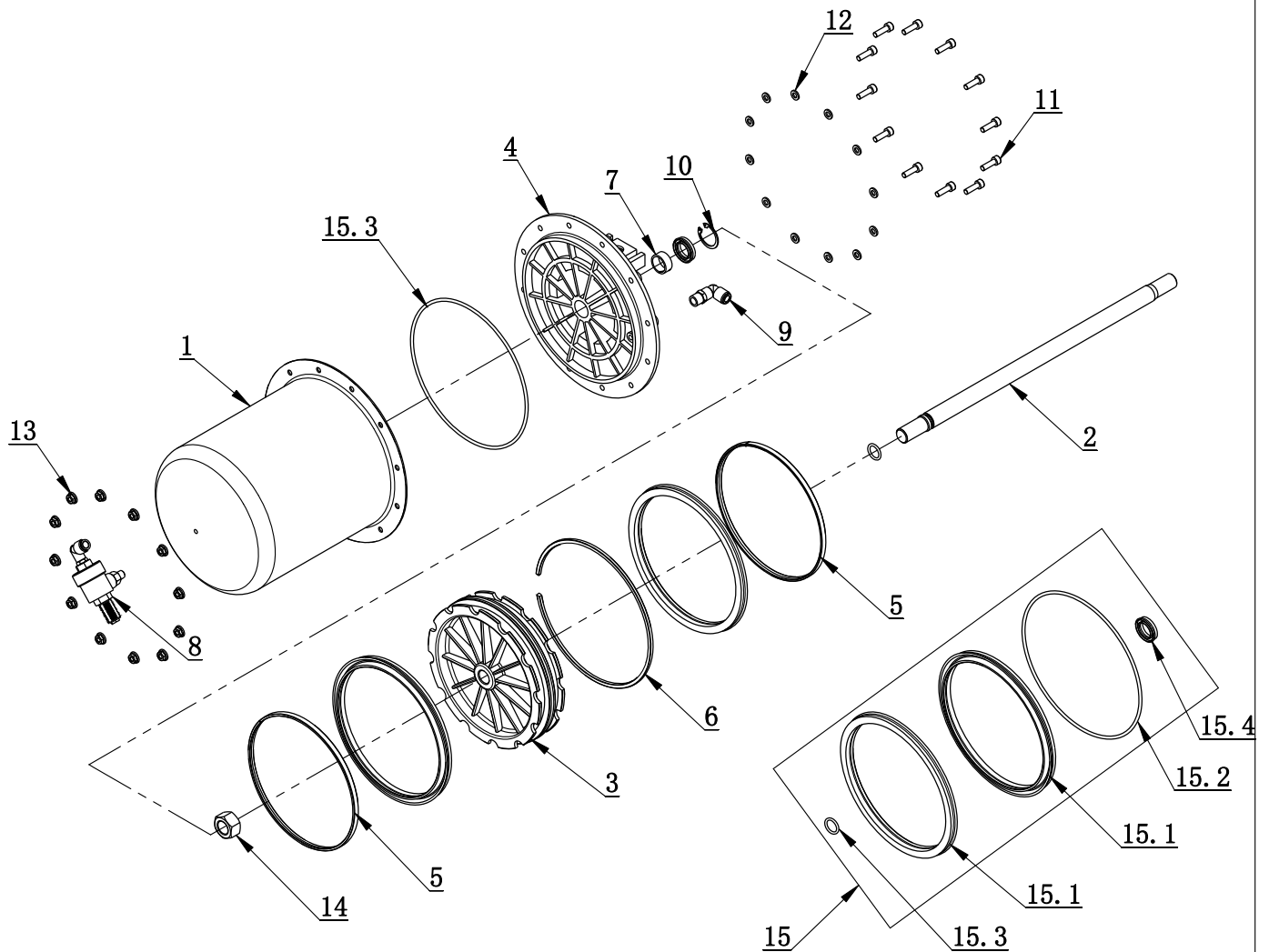

ITEM	PART. No	DESCRIPTION.	QT. Y
1	CT-LS-1100002	CYLINDER BODY	1
2	CT-LS-2100001	CYLINDER PISTON ROD	1
3	CT-LS-1100003	PISTON	1
4	CT-LS-1100004	CYLINDER COVER	1
5	CT-LS-1100006	CLAMP RING	2
6	CT-LS-1100007	PISTON SUPPORT RING	1
7	CT-LS-1100008	GUIDER SPACER	1
8	CT-LS-1320000	QUICK DEFLATE VALVE ON BODY	1
9	FPL 8-02	INSERT ELBOW Φ8, R1/4	1
10	GB893. 2-30	ELASTIC RETAINING RING B-TYPE	1
11	GB70. 1-M6×20	INNER HEXA CYLINDRICAL SCREW	12
12	GB95-6	FLAT WASHER	12
13	GB6177. 1-M6	HEXA FLANGE NUT	12
14	GB6171- M18×1. 5	NUT THIN TOOTH	1
15	CT-LS-1110000	CYCLINDER SEALING PARTS ASSEMBLY	1
15. 1	CT-LS-1100009	Y-RING	2
15. 2	GB3452. 1-185×3. 55-G	O-RING G TYPE	1
15. 3	GB3452. 1-15. 5×2. 65-G	HYDRAULIC-PNEUMATIC RUBBER O-RING G TYPE	1
15. 4	CT-Y-0160007	SEAL-ROD, CYLINDR	1

CT-XD-3000000

REVISION 13A-01

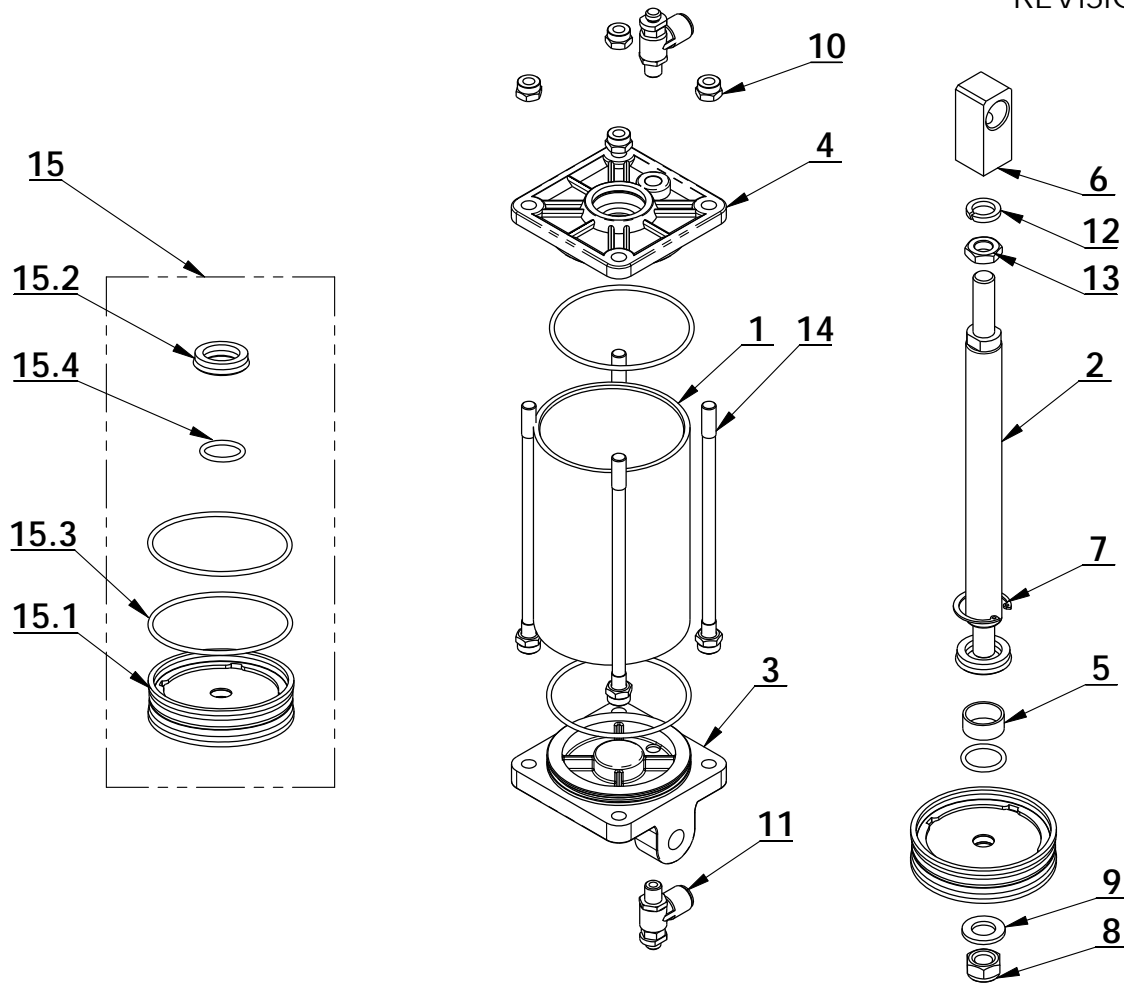

ITEM	PART. No	DESCRIPTION.	QT. Y
1	CT-XD-1000001	CYLINDER BODY	1
2	CT-XD-2000002	PISTON ROD	1
3	CT-XD-1000005	CYLINDER REAR COVER	1
4	CT-Y-4120004	CYLINDER FRONT COVER	1
5	JH1 2010	BEARING-SLIDE	1
6	CT-XD-1000004	SHAFT CONNECTOR	1
7	GB893. 1-30	ELASTIC RETAINING RING A-TYPE	1
8	GB889. 1-M12	1- TYPE PREVAILING TORQUE TYPE HEXAGON LOCK NUT	1
9	GB95-12	FLAT WASHER	1
10	GB889. 1-M8	1-TYPE PREVAILING TORQUE TYPE HEXAGON LOCK NUT	8
11	FJSC 8-01	ELBOW SPEED CONTROLLER	2
12	GB93-12	STANDARD SPRING WASHER	1
13	GB/T6172. 1-M12	HEXANGULAR THIN NUT	1
14	CT-XD-1000003	BAR	4
15	CT-XD-2100000	CYCLINDER SEALING PARTS ASSEMBLY	1
15. 1	CT-Y-4120006	PISTON	1
15. 2	CT-Y-0160007	SEAL-ROD, CYLNDR	1
15. 3	GB3452. 1-75×2. 65	HYDRAULIC-PNEUMATIC RUBBER O-RING G TYPE	1
15. 4	GB3452. 1-20×2. 65	HYDRAULIC-PNEUMATIC RUBBER O-RING G TYPE	1

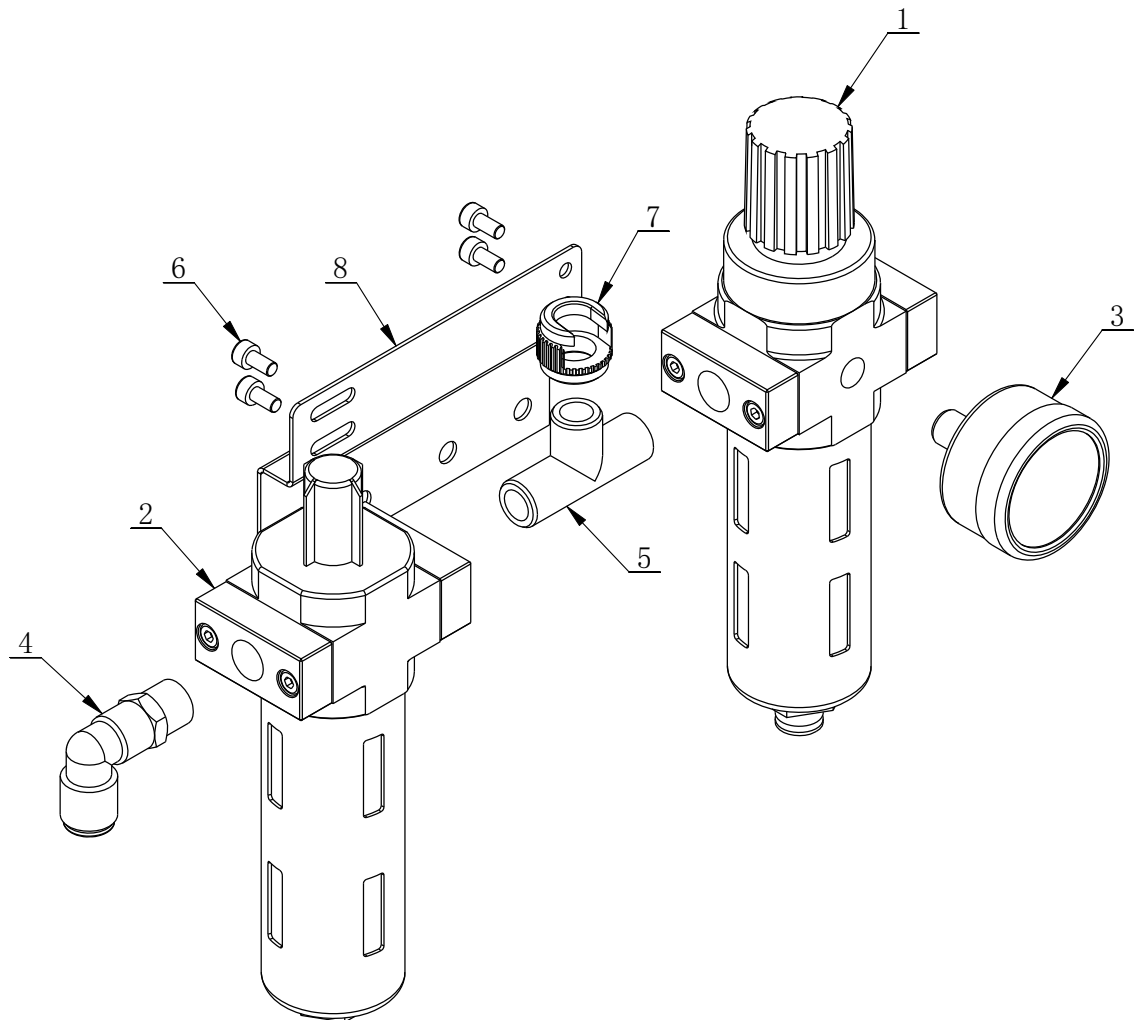

ITEM	PART. No	DESCRIPTION.	QT. Y
1	CT-F-2000010	PRESSURE ADJUST VALVE AND WATER CUP	1
2	CT-F-2000020	OIL CUP	1
3	CT-F-2000003	PRESSURE GAUGE	1
4	FPL 8-02	INSERT ELBOW $\Phi 8$, R1/4	1
5	PEH 02-02	FAMALE UNION TEE	1
6	GB70. 1-M4 \times 8	INNER HEXA CYLINDRICAL SCREW	4
7	C-01-1500004	OPEN NUT	1
8	CT-F-2000040	AIR REGULATOR BRACKET	1

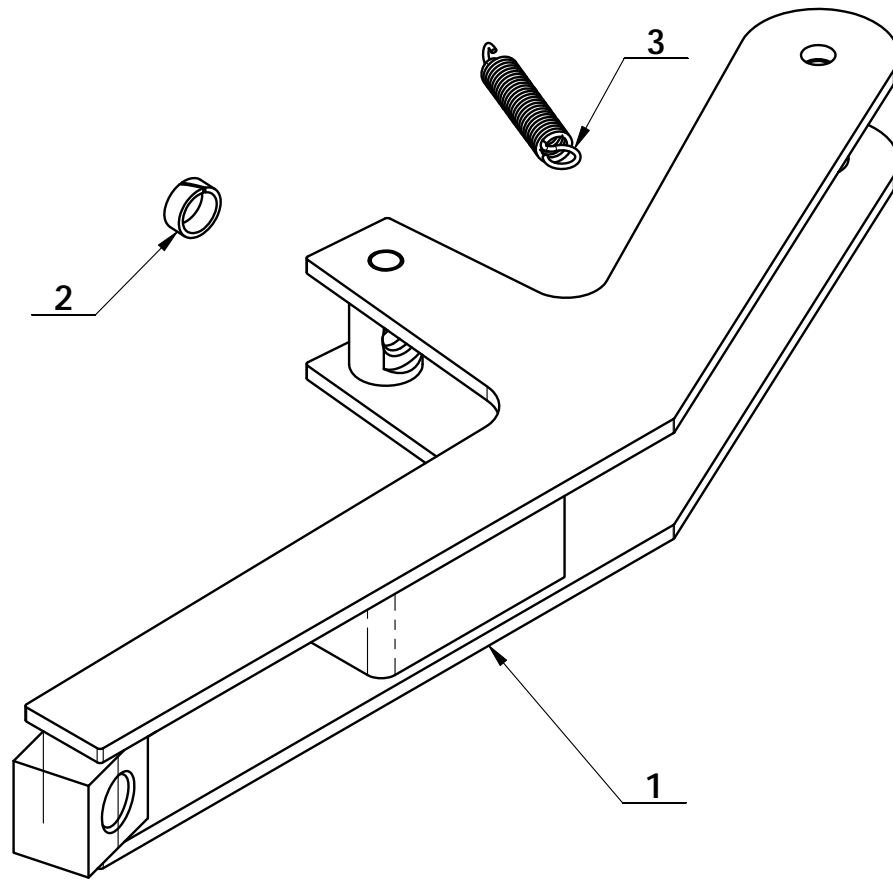

ITEM	PART. No	DESCRIPTION.	QT. Y
1	CT-B-2100000	BEAD BREAKER	1
2	CT-B-2000001	SLIDE SPACER	1
3	CT-B-2000002	SPRING	1

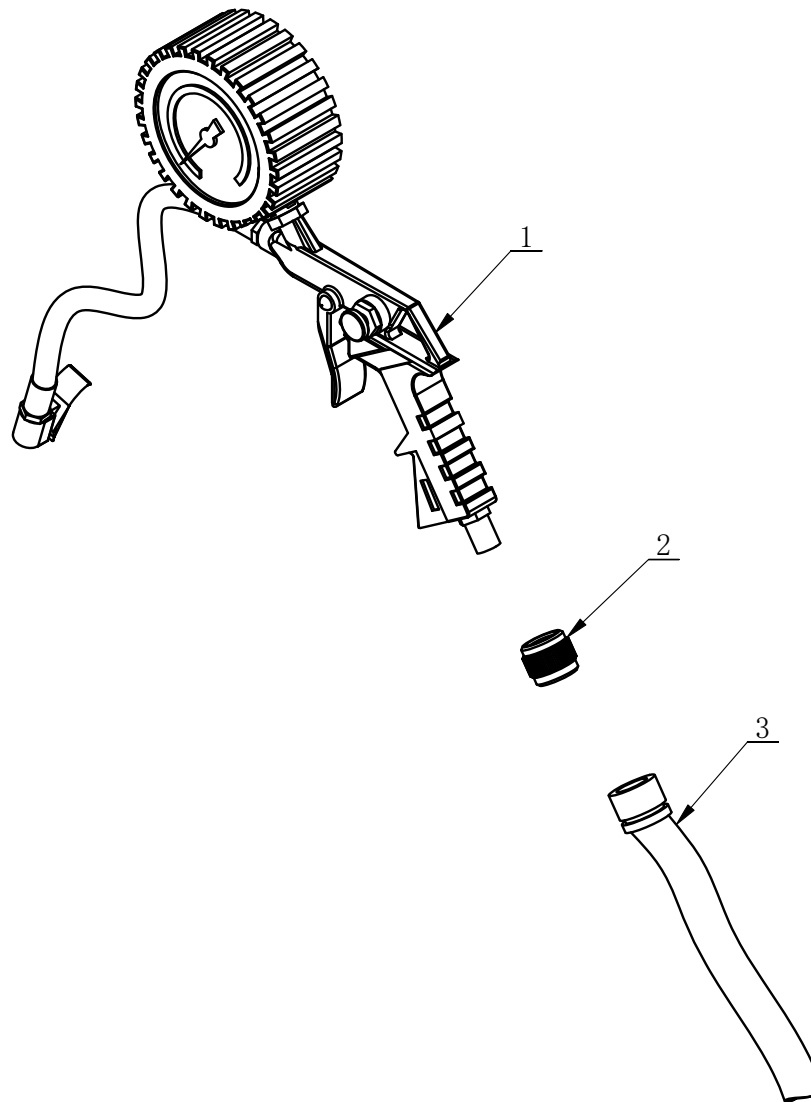

ITEM	PART. No	DESCRIPTION.	QT. Y
1	CT-P-1000001	INFLATING GUN	1
2	C-01-1500004	OPEN NUT	1
3	CT-P-1000002	INFLATION HOSE	1

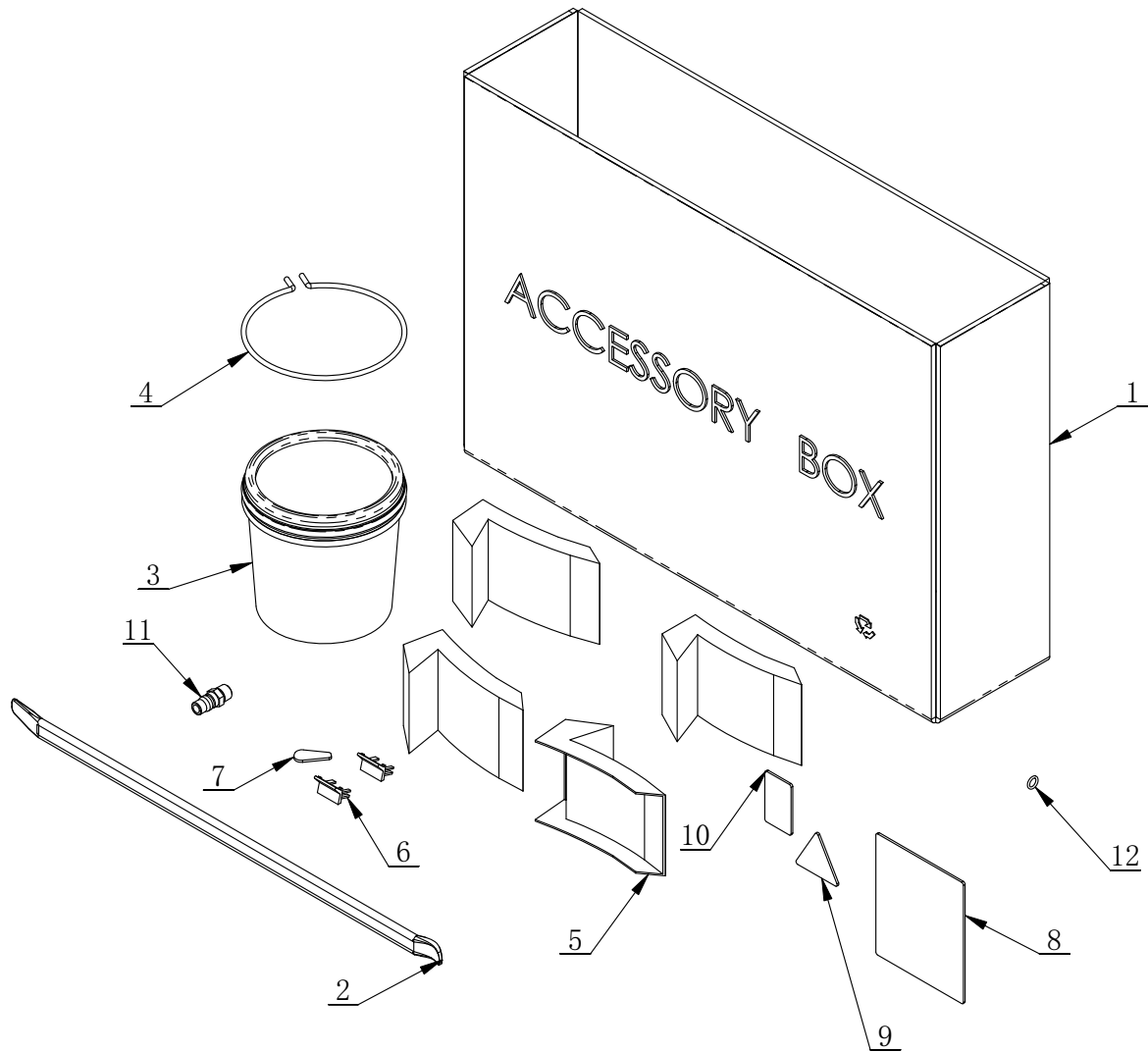

ITEM	PART. No	DESCRIPTION.	QT. Y
1	C-54-8000002	ACCESSORY BOX	1
2	C-54-8000003	20INCH CROWBAR	1
3	C-54-8100000	GREASE CONTAINER	1
4	C-54-8000004	BRACKET	1
5	C-54-8000005	CLAMP PROTECTION COVER	4
6	C-54-8000006	SHEATH	2
7	C-54-8000007	PLASTIC COVER	1
8	C-54-8000008	USER MANUAL	1
9	C-54-8000009	PASS CARD	1
10	C-54-8000010	GUARANTEE	1
11	C-54-8000011	AIR SUPPLY CONNECTOR	1
12	GB / T 3452.1-2005 8x2.65	HYDRAULIC-PNEUMATIC RUBBER O-RING G TYPE	1