

# Exploded Drawing

GT885E

C-7C-0000000

Organization :

To examine :

Approval :

Version: A-02

2012.12.30

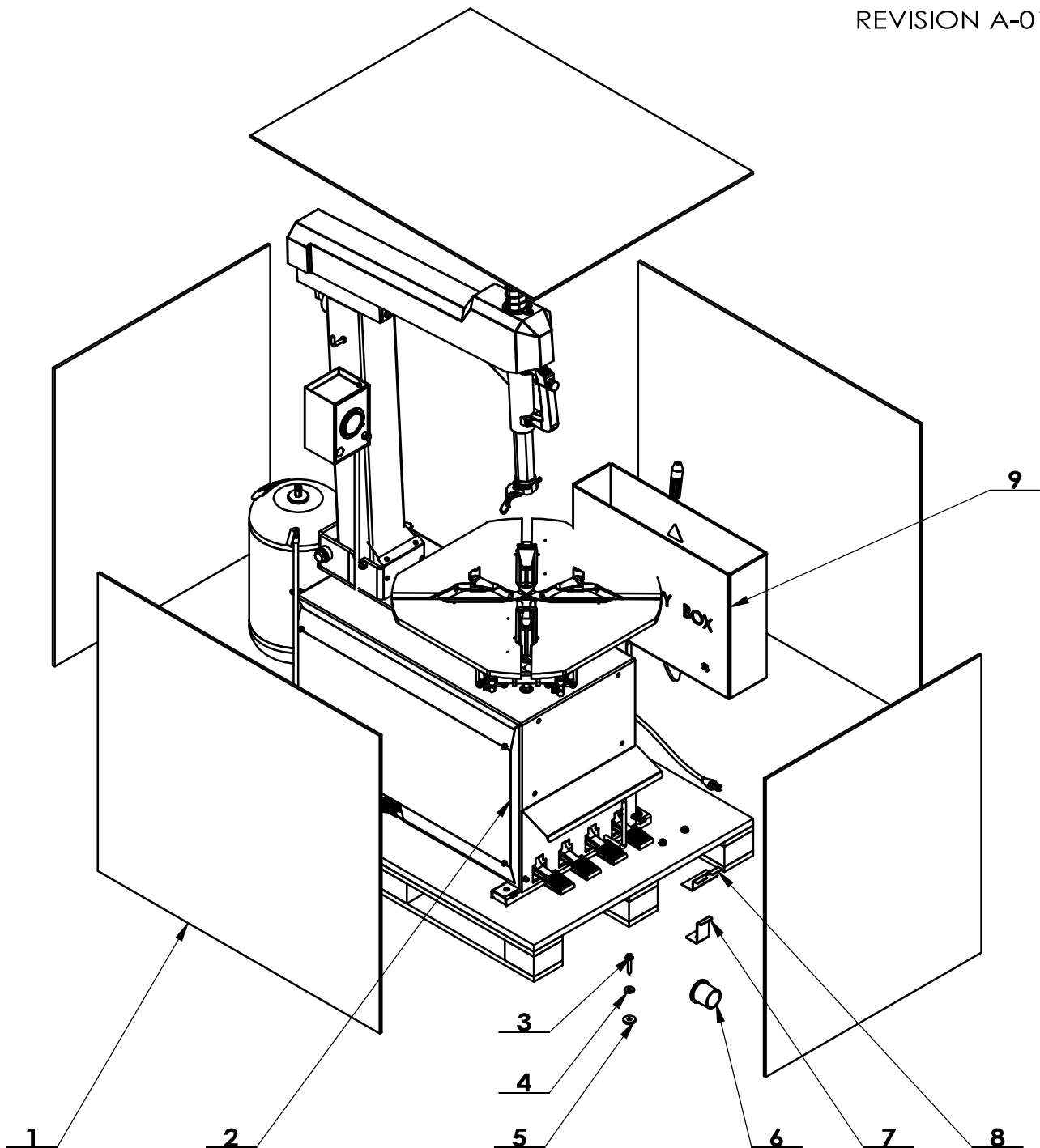

ITEM	PART. No	DESCRIPTION.	QT. Y
1	C-7C-9100000	PACKAGE	1
2	C-7C-1000000	885IT E	1
3	GB16824. 1-ST8×50 C	HEXA FLANGE TAPPING SCREW	6
4	GB96. 2-8	LARGE WASHER C GRADE	4
5	C-70-9000003	PACKAGE SPACER	4
6	C-70-9000004	SPACER PACKAGE	1
7	C-70-9000002	PACKAGE SCREW WASHER	1
8	C-70-9000001	PACKAGE HOOK	1
9	C-70-8000000	ACCESSORY BOX	1

REVISION A-02

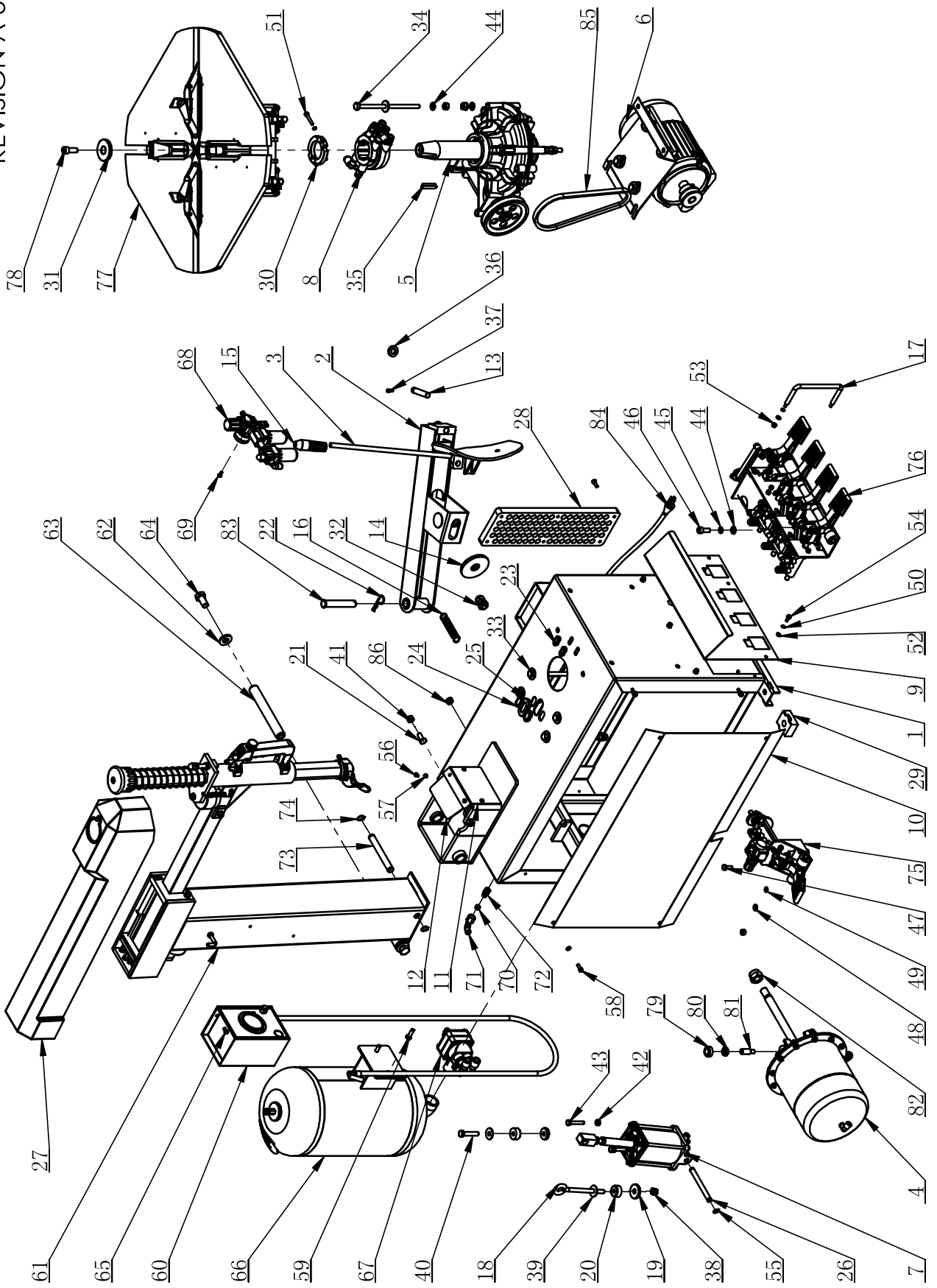

ITEM	PART. No	DESCRIPTION.	QT. Y
1	C-7C-1100000	BODY WELDING	1
2	CT-B-4000000	BEAD BREAKING ARM ASSEMBLY	1
3	CT-C-3100000	BEAD BREAKER BLADE	1
4	CT-LS-2000000	BEAD BREAKER CYLINDER ASSEMBLY	1
5	CT-J-4100000	GEARBOX ASSEMBLY	1
6	CT-DJ-0212112	MOTOR ASSEMBLY	1
7	CT-XD-3000000	PULL-OUT CYLINDER D80X80	1
8	CT-Q-2000000	AIR GUIDER ASSEMBLY	1
9	C-7C-1000001	PROTECTIVE COVER	1
10	C-7C-1000002	SIDE PANEL	1
11	C-7C-1000003	PROTECTIVE PLATE	1
12	C-7C-1000004	RUBBER PLATE	1
13	CT-C-3000001	ROTATION SPINDLE	1
14	C-10-1000003	RUBBER PLATE	1
15	C-54-1300011	HANDLE COVER	1
16	CT-B-3000001	SPRING	1
17	C-90-1000012	PROTECTIVE ROD	1
18	C-70-1000012	CONNECTION ROD	1
19	TB-P-0100005	WASHER	1
20	C-70-1000013	WASHER $\Phi 30 \times \Phi 10 \times 15$	2
21	C-70-1000005	BOLT	2
22	C-01-100000B	CIRCLIP	1
23	C-90-1000003	PLUG A	2
24	C-90-1000004	PLUG C	2
25	C-90-1000002	PLUG B	1
26	C-70-1000004	PIN SHAFT	1
27	C-70-1000007	PROTECTIVE COVER	1
28	C-10-1000001	RIM SUPPORT	1
29	C-54-1000005	RUBBER FOOT	4
30	CT-Q-0000001	CLAMP RING	1
31	CT-Y-0100001	PRESS COVER	1
32	C-01-1000004	CABLE CONNECTOR	1
33	GB/5781-M10×160	HEXANGULAR BOLT	2
34	GB5780-M10X200	HEXANGULAR BOLT	4
35	GB1096-C12×8×45	COMMON FLAT KEY	1
36	GB955-14	WAVE-FORM SPRING WASHER	1
37	GB85-M6×12	SQUARE HEAD CYLINDRICAL TERMINUS SET SCREW	1
38	GB889. 1-M10	1-TYPE PREVAILING TORQUE TYPE HEXAGON LOCK NUT	2
39	GB96. 1-10	LARGE WASHER A GRADE	11
40	GB5782-M10×50	HEXANGULAR BOLT	1
41	GB41-M10	HEXANGULAR NUT	16
42	GB41-M8	HEXANGULAR NUT	6
43	GB5782-M8×45	HEXANGULAR BOLT	2

ITEM	PART. No	DESCRIPTION.	QT. Y
44	GB95-10	FLAT WASHER	16
45	GB93-10	STANDARD SPRING WASHER	2
46	GB70. 1-M10×25	INNER HEXA CYLINDRICAL SCREW	2
47	GB5783-M8×20	HEXANGULAR BOLT	2
48	GB95-8	FLAT WASHER	4
49	GB93-8	STANDARD SPRING WASHER	4
50	GB93-6	STANDARD SPRING WASHER	9
51	GB70. 1-M6×35	SCREW M6X35	2
52	GB95-6	FLAT WASHER	11
53	GB41-M6	HEXANGULAR NUT	2
54	GB70. 1-M6×12	INNER HEXA CYLINDRICAL SCREW	5
55	GB894. 1-12	SHAFT ELATIC BIG RETAINING RING A-TYPE	2
56	GB818-M5×10-H	CROSS PANHEAD SCREW	4
57	GB41-M5	HEXANGULAR NUT	2
58	GB70. 1-M6×16	INNER HEXA CYLINDRICAL SCREW	10
59	GB5783-M8×25	HEXANGULAR BOLT	2
60	CT-K-3100000	INFLATOR COVER ASSEMBLY	1
61	C-7C-1200000	HORIZONTAL ARM	1
62	C-70-1000008	WASHER	2
63	C-70-1000009	ROTATION SHAFT	1
64	GB5781-M16×30	HEXANGULAR BOLT	2
65	GB70. 1-M6×10	INNER HEXA CYLINDRICAL SCREW	2
66	CT-K-4100000	AIR TANK	1
67	CT-K-2200000	QUICK EXHAUST VALVE ASSY	1
68	CT-F-3122111	AIR REGULATOR ASSEMBLY	1
69	GB818-M5×12-H	CROSS PANHEAD SCREW	2
70	C-70-1000018	JOINT SEALING GASKET	1
71	KC-ZJNKZD-2-8	INSERT ELBOW $\Phi 8, R1/4$	1
72	KC-ZTZD-2-8	INSERT FITTING $\Phi 8, R1/4$	1
73	C-70-1000010	PULL-OUT SHAFT	1
74	GB894. 1-16	SHAFT ELATIC BIG RETAINING RING A-TYPE	2
75	CT-K-1100000	QUICK INFLATION PEDAL ASSY	1
76	CT-D-4100000	PEDAL ASSEMBLY	1
77	CT-Y-2100000	TURNTABLE ASSEMBLY	1
78	GB70. 1-M12×30	INNER HEXA CYLINDRICAL SCREW	1
79	C-70-1000011	SEALED COVER	1
80	GB6172. 1-M14	HEXANGULAR THIN NUT	2
81	C-70-1000021	INNER HEXA CYLINDRICAL TERMINUS SET SCREW	2
82	GB889. 1-M18X1.5	1-TYPE PREVAILING TORQUE TYPE HEXAGON LOCK NUT	1
83	GB882-18×100	PIN SHAFT	1
84	C-70-1000020	POWER CABLE ASSEMBLY	1
85	CT-DJ-0000007	BELT A-25	1
86	C-70-1000006	HELPER RUBBE PLUG	4

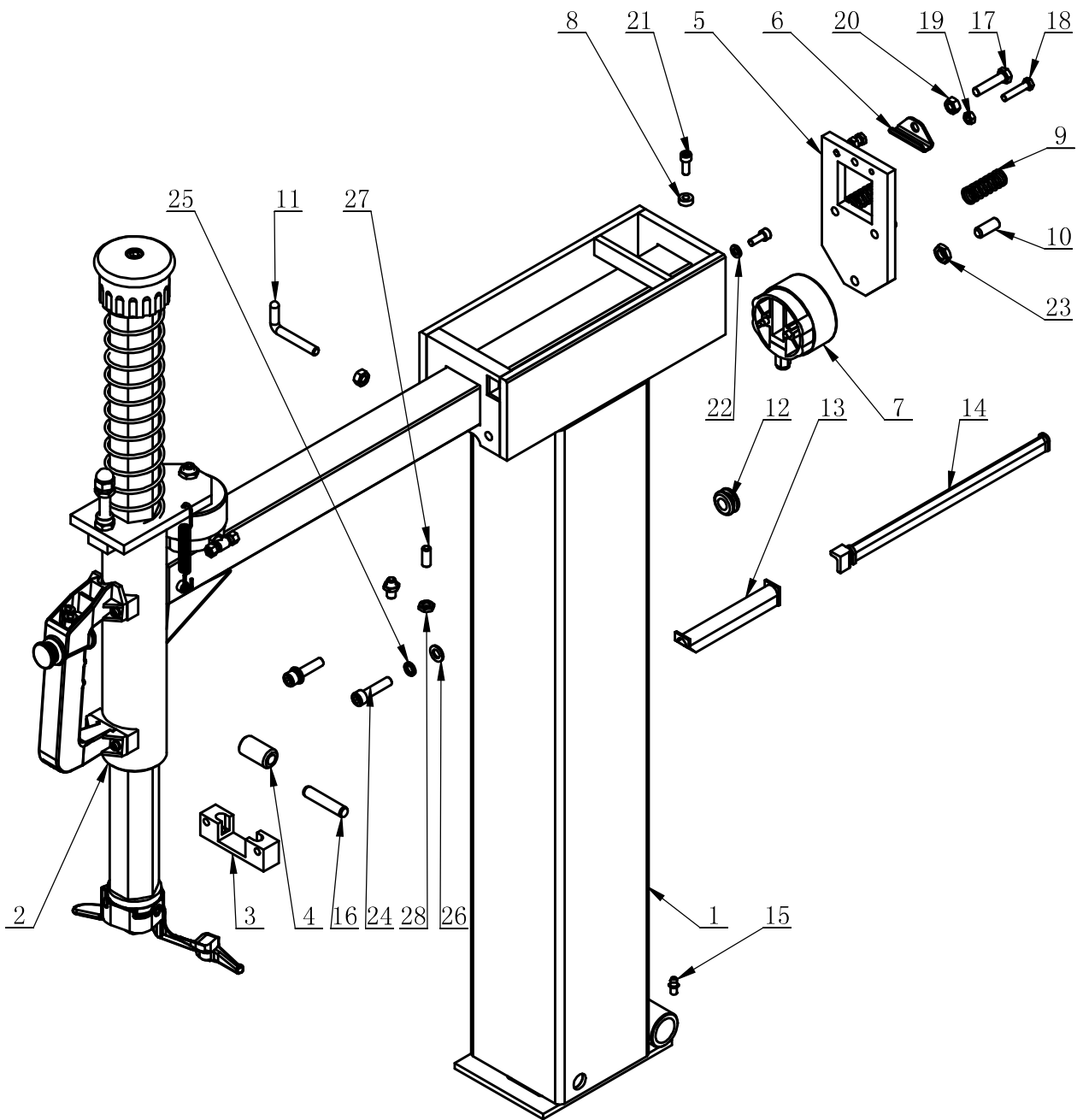

ITEM	PART. No	DESCRIPTION.	QT. Y
1	C-7C-1210000	VERTICAL COLUMN	1
2	C-7C-1220000	HORIZONTAL ARM	1
3	C-7C-1200001	TELEFLEX BASE	1
4	C-7C-1200002	TELEFLEX	1
5	C-70-1230000	SQUARE LOCK PLATE	1
6	C-70-1200008	SLIDER	1
7	C-70-1240000	LOCKING CYLING ASSY	1
8	C-70-1200001	SPACER	1
9	C-70-1200002	PRESS SPRING	2
10	C-70-1200010	INNER HEXA FLAT TERMINUS SET SCREW	1
11	C-60-1000002	INFLATING GUN HOOK	1
12	C-70-1200009	STOP-UP	1
13	C-70-1200004	PIPE GUIDER	1
14	C-70-1200003	PIPE GUIDER	1
15	c-90-1200004	OIL CUP	1
16	GB119.2-10×50	CYLINDRICAL PIN	1
17	GB5781-M8×35	HEXANGULAR BOLT	1
18	GB5781-M6×30	HEXANGULAR BOLT	2
19	GB6170-M6	HEXANGULAR NUT 1-TYPE	2
20	GB6170-M8	HEXANGULAR NUT 1-TYPE	2
21	GB70.1-M6×16	INNER HEXA CYLINDRICAL SCREW	2
22	GB95-6	FLAT WASHER	1
23	GB6173-M10×1.0	HEXA THIN NUT	1
24	GB70.1-M8×35	INNER HEXA CYLINDRICAL SCREW	2
25	GB93-8	STANDARD SPRING WASHER	2
26	GB95-8	FLAT WASHER	2
27	GB77-M8×20	INNER HEXA FLAT TERMINUS SET SCREW	2
28	GB6172.1-M8	HEXANGULAR THIN NUT	2

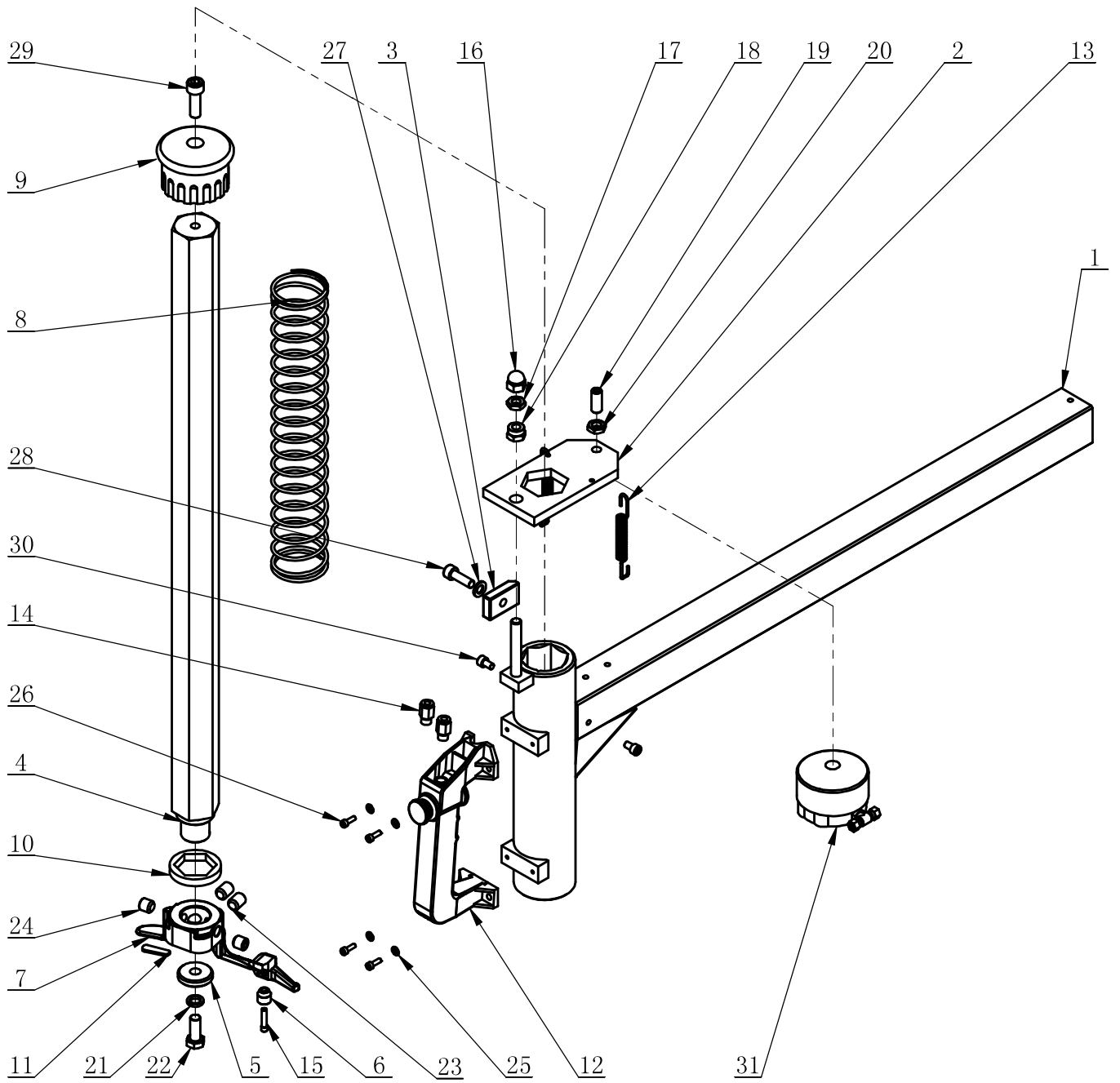



ITEM	PART. No	DESCRIPTION.	QT. Y
1	C-7C-1221000	HORIZONTAL ARM WELDING	1
2	C-7C-1220001	HEXANGULAR LOCK PLATE	1
3	C-70-1220005	POSITIONING BLOCK	1
4	C-86-1320001	HEXAGON SHAFT	1
5	C-54-1300008	PRESS WASHER	1
6	C-54-1300009	ROLLER	1
7	C-31-1300013	BRACKET RECIEVER, BEAD ROLLER TOOL-4	1
8	C-80-1320003	VERTICAL SHAFT SPRING	1
9	C-90-1220004	VERTICAL SHAFT COVER	1
10	BLFJZD	SHOCK ABSORBER WASHER	1
11	BNTD-L	PLASTIC COVER	1
12	C-70-1224000	HANDLE CONTROLING VALVE	1
13	BLH2. 0×9×95	SPRING	2
14	BNCZZ6-G1 / 8	MALE STRAIGHT	2
15	JD6×25	ROLLER BOLT	1
16	GB923-M10	CAP NUT	1
17	GB6172. 1-M10	HEXANGULAR THIN NUT	1
18	GB889. 1-M10	1-TYPE PREVAILING TORQUE TYPE HEXAGON LOCK NUT	1
19	JD10×1×25	INNER HEXA FLAT TERMINUS SET SCREW	1
20	GB6173-M10×1. 0	HEXA THIN NUT	1
21	GB93-10	STANDARD SPRING WASHER	1
22	GB5783-M10×25	HEXANGULAR BOLT	1
23	GB77-M12×16	INNER HEXA FLAT TERMINUS SET SCREW	2
24	GB77-M12×12	INNER HEXA FLAT TERMINUS SET SCREW	2
25	GB95-4	FLAT WASHER	4
26	GB70. 1-M4×12	INNER HEXA CYLINDRICAL SCREW	4
27	GB95-8	FLAT WASHER	1
28	GB70. 1-M8×25	INNER HEXA CYLINDRICAL SCREW	1
29	GB70. 1-M10×30	INNER HEXA CYLINDRICAL SCREW	1
30	GB70. 1-M6×10	INNER HEXA CYLINDRICAL SCREW	2
31	C-70-1223000	LOCKING CYLINDER ASSY	1

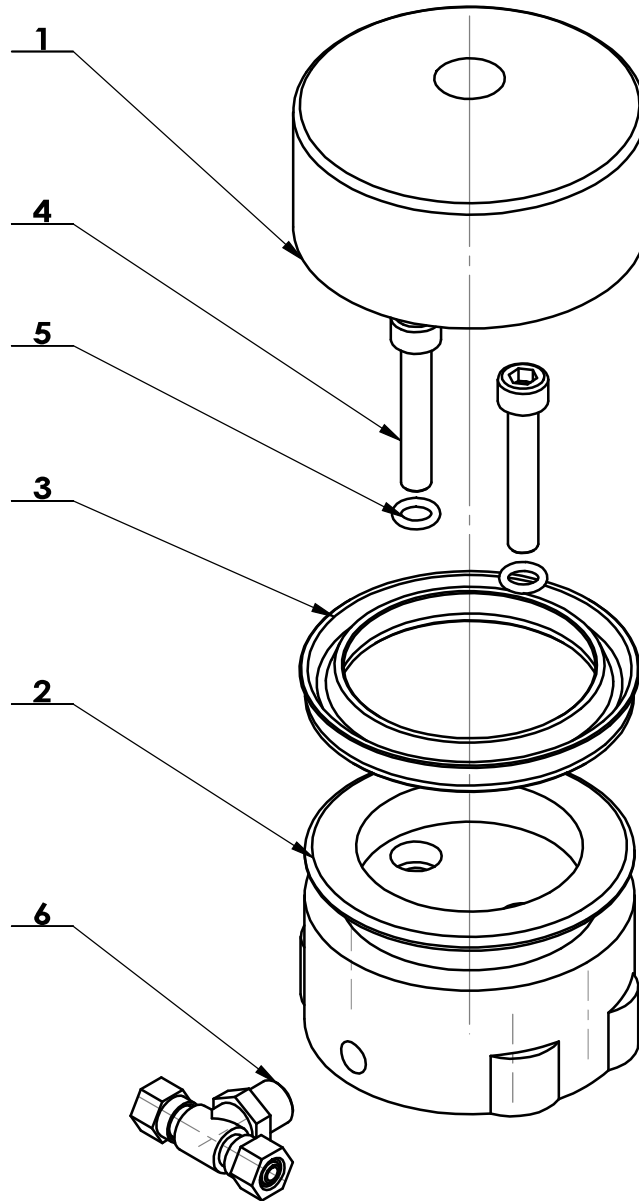

ITEM	PART. No	DESCRIPTION.	QT. Y
1	C-70-1223001	LOCK TURNTABLE CYLINDER HEAD	1
2	C-70-1223002	LOCK TURNTABLE CYLINDER HOUSING	1
3	C-70-1223003	Y-RING	1
4	GB70. 1-M6×35	INNER HEXA CYLINDRICAL SCREW	2
5	GB3452. 1-6×1.8-G	O-RING G TYPE	2
6	PBS 6-01	MALE BRANCH TEE NUT	1

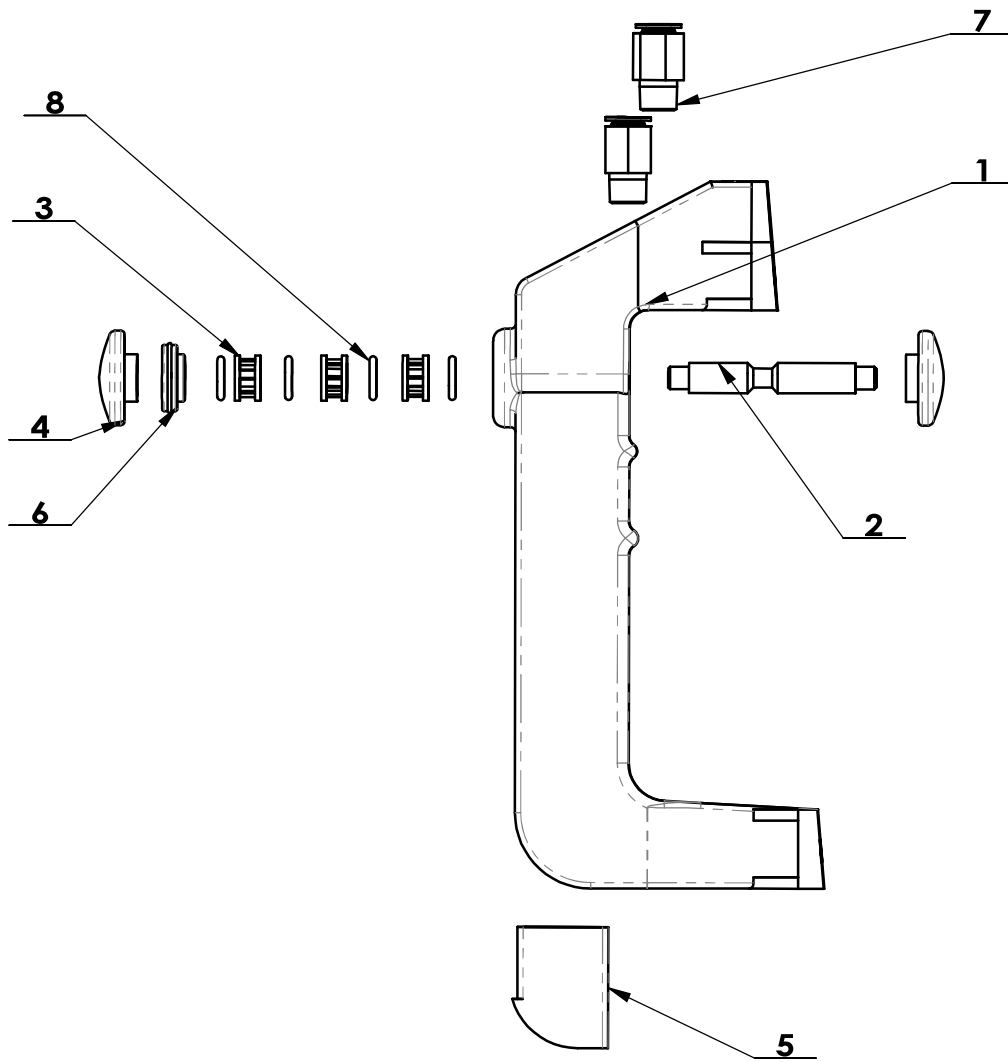

ITEM	PART. No	DESCRIPTION.	QT. Y
1	C-70-1224001	HANDLE CONTROL VALVE	1
2	C-70-1224002	VALVE ROD	1
3	C-70-1224003	VALVE SPACER	3
4	C-70-1224004	FRONT COVER	2
5	C-70-1224005	REAR COVER	1
6	C-70-1224006	FRONT SEALING COVER	1
7	FPC 6-01	MALE STRAIGHT	2
8	GB3452. 1-8×1.8-G	O-RING G TYPE	4

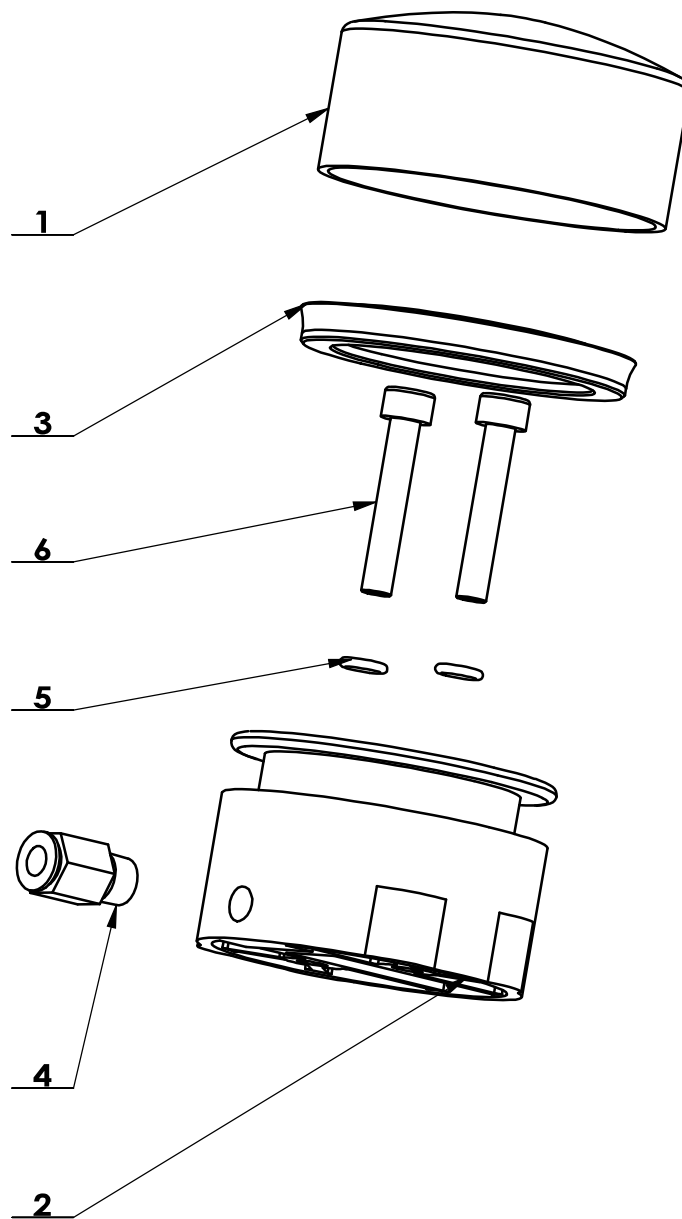

ITEM	PART. No	DESCRIPTION.	QT. Y
1	C-70-1223001	LOCK TURNTABLE CYLINDER HEAD	1
2	C-70-1223002	LOCK TURNTABLE CYLINDER HOUSING	1
3	C-70-1223003	Y-RING	1
4	FPC 6-01	MALE STRAIGHT	1
5	GB3452. 1-6×1. 8-G	O-RING G TYPE	2
6	GB70. 1-M6×35	INNER HEXA CYLINDRICAL SCREW	2

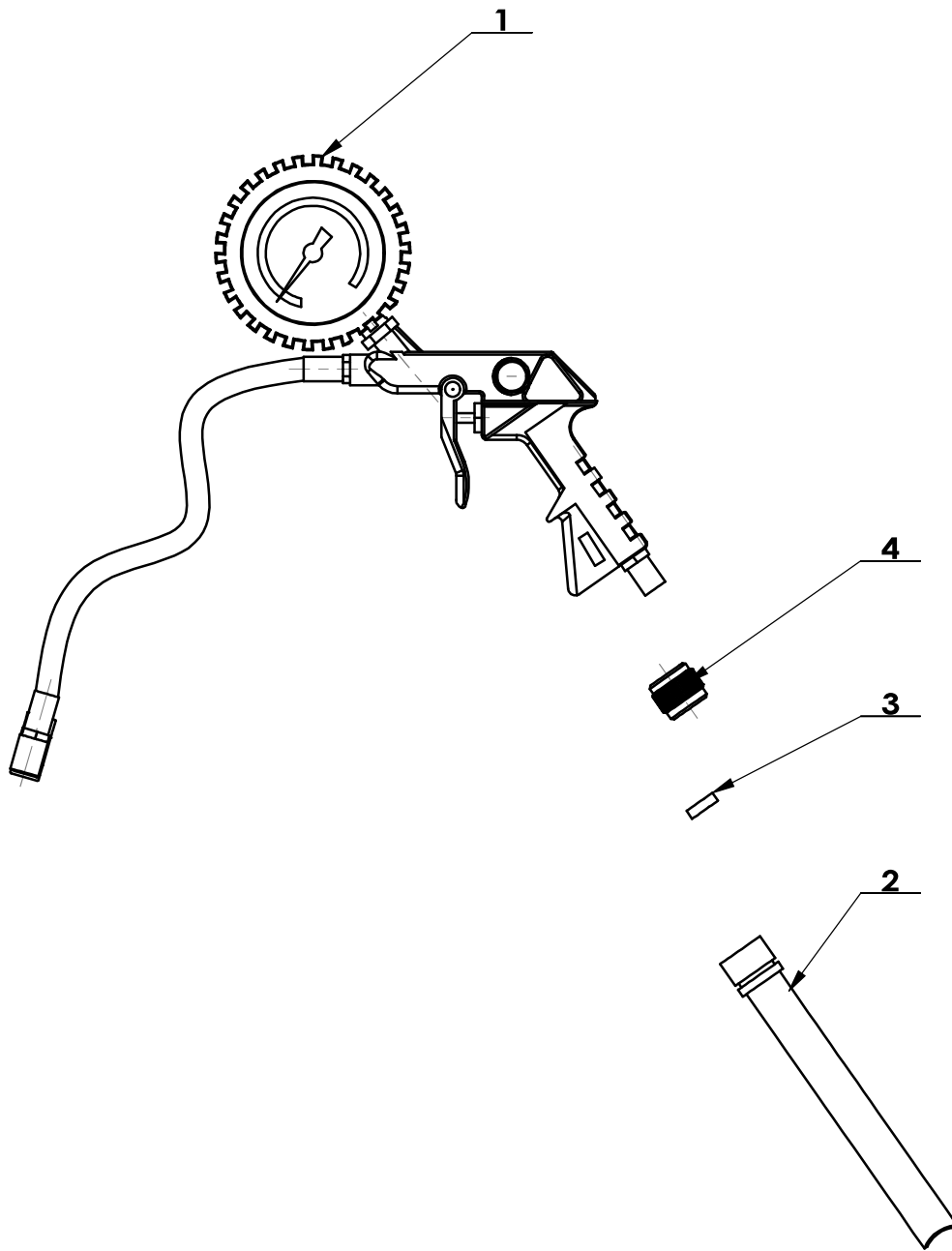

ITEM	PART. No	DESCRIPTION.	QT. Y
1	C-01-1500001	INFLATING GUN	1
2	C-01-1500002	INFLATION HOSE	1
3	C-01-1500003	RING D13XD7X4	1
4	C-01-1500004	OPEN NUT	1

REVISION A-03

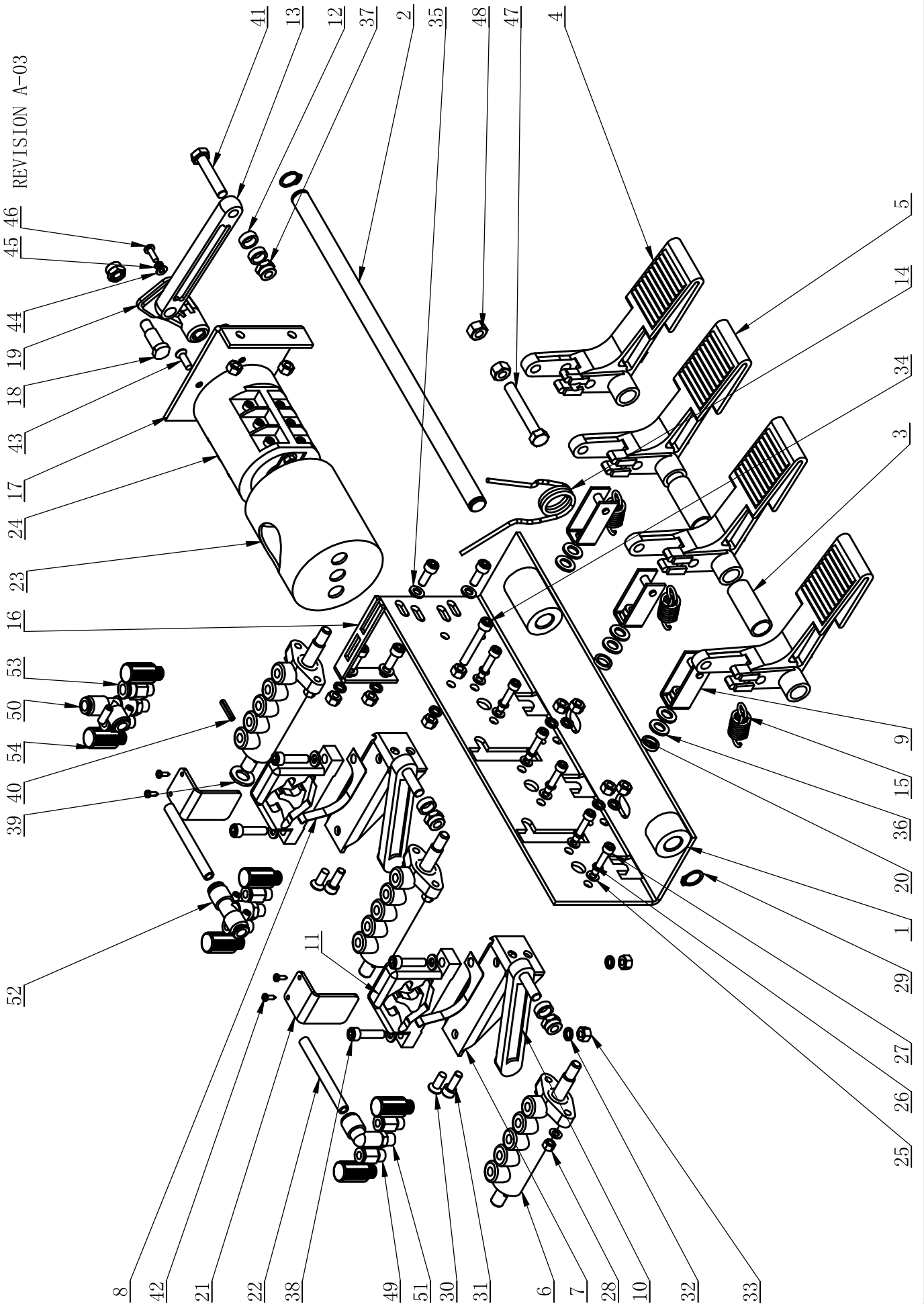

ITEM	PART. No	DESCRIPTION.	QT. Y
1	CT-D-4110000	PEDAL SUPPORT WELDING	1
2	CT-D-4100001	BOTTOM SHAFT	1
3	CT-D-2100001	SPACER	2
4	CT-D-2100006	PEDAL	1
5	CT-D-2100007	PEDAL	3
6	CT-D-2140000	VALVE	3
7	CT-D-2120000	CAM BRACKET WELDING	2
8	CT-D-2100004	SPRING PLATE	2
9	CT-D-2130000	BRACKET	3
10	CT-D-1100008		2
11	CT-D-1100009	CAM	2
12	CT-D-2100005	SPACER	4
13	CT-D-2100011	CONNECTION ROD	1
14	CT-D-2100002	TORSION SPRING	1
15	CT-D-2100003	SPRING	3
16	CT-D-2100010	TORSION SPRING BRACKET	1
17	CT-D-2100008	SWITCH SUPPORT	1
18	CT-D-2100012	ROTATION SHAFT	1
19	CT-D-1100010	REVERSE LEVER	1
20	CT-D-1100016	SPACER	2
21	CT-D-1100011	CAM BAFFLE PLATE	2
22	CT-D-2100013	HOSE	2
23	CT-D-1100014	SWITCH COVER	1
24	CT-D-1100018	SWITCH	1
25	GB95-5	FLAT WASHER	12
26	GB93-5	STANDARD SPRING WASHER	6
27	GB70. 1-M5×25	INNER HEXA CYLINDRICAL SCREW	6
28	GB41-M5	HEXANGULAR NUT	6
29	GB894. 1-14	SHAFT ELATIC BIG RETAINING RING A-TYPE	2
30	GB819. 1-M6×16-H	CROSS COUNTERSUNK SCREW STEEL 4.8 GRADE	2
31	GB70. 1-M6×16	INNER HEXA CYLINDRICAL SCREW	6
32	GB93-6	STANDARD SPRING WASHER	11
33	GB41-M6	HEXANGULAR NUT	14
34	GB70. 1-M6×40	INNER HEXA CYLINDRICAL SCREW	1
35	GB95-6	FLAT WASHER	8
36	GB95-8	FLAT WASHER	6
37	GB889. 1-M8	1-TYPE PREVAILING TORQUE TYPE HEXAGON LOCK NUT	6
38	GB70. 1-M6×25	INNER HEXA CYLINDRICAL SCREW	4
39	GB95-10	FLAT WASHER	1
40	GB879. 1-4×20	ELASTIC CYLINDRICAL PIN, HEAVY	1
41	GB5781-M8×40	HEXANGULAR BOLT	1
42	GB845-ST2. 9×9.5 H C	CROSS PANHEAD TAPPING SCREW	4
43	GB819. 1-M5×16-H	CROSS COUNTERSUNK SCREW STEEL 4.8 GRADE	4
44	GB95-4	FLAT WASHER	1
45	GB93-4	STANDARD SPRING WASHER	1
46	GB818-M4×12-H	CROSS PANHEAD SCREW	1
47	GB5782-M8×55	HEXANGULAR BOLT	1
48	GB41-M8	HEXANGULAR NUT	2
49	FPC 6-01	MALE STRAIGHT	4
50	FPD 8-01	MALE RUN TEE	1
51	FPL 8-01	INSERT ELBOW Φ8, R1/8	1
52	FPB 8-01	MALE BRANCH TEE	1
53	FPC 8-01	MALE STRAIGHT	2
54	FSK 01	PLASTIC PARTICLE SILENCER	6





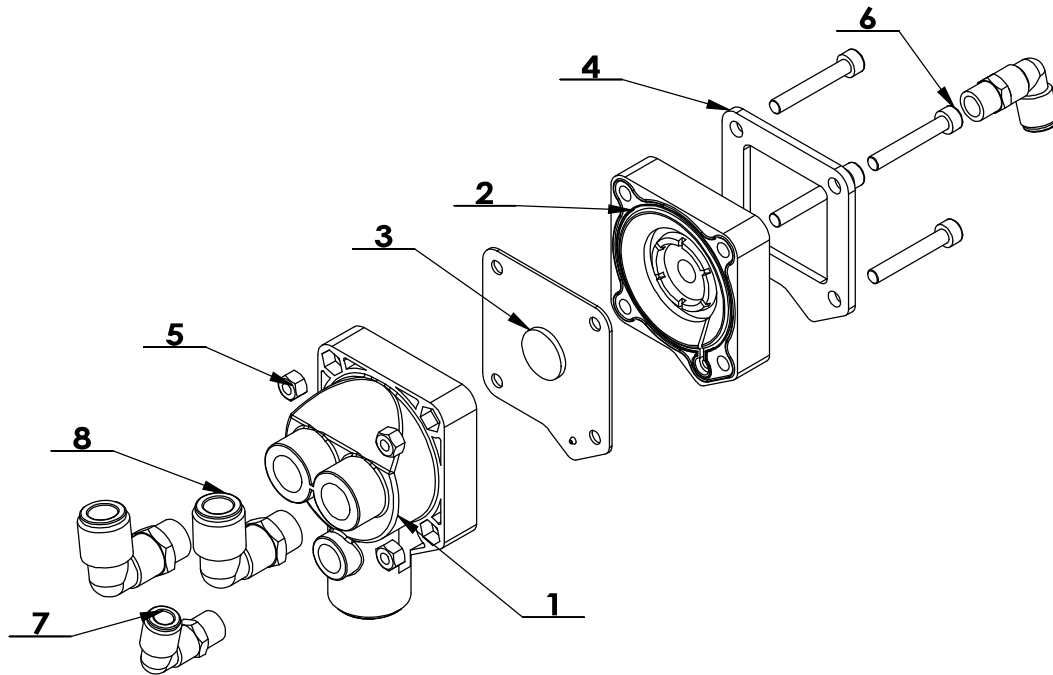

ITEM	PART. No	DESCRIPTION.	QT. Y
1	CT-K-2200002	LOWER COVER OF QUICK DEFLATE VALVE	1
2	CT-K-2200001	COVER OF QUICK DEFLATE VALVE	1
3	CT-K-2210000	FILM CHIP	1
4	CT-K-2200003	PRESS WASHER	1
5	GB41-M6	HEXANGULAR NUT	4
6	GB70. 1-M6×40	INNER HEXA CYLINDRICAL SCREW	4
7	FPL 8-02	INSERT ELBOW Φ8, R1/4	2
8	FPL 12-03	INSERT ELBOW Φ12 R3/8"	2

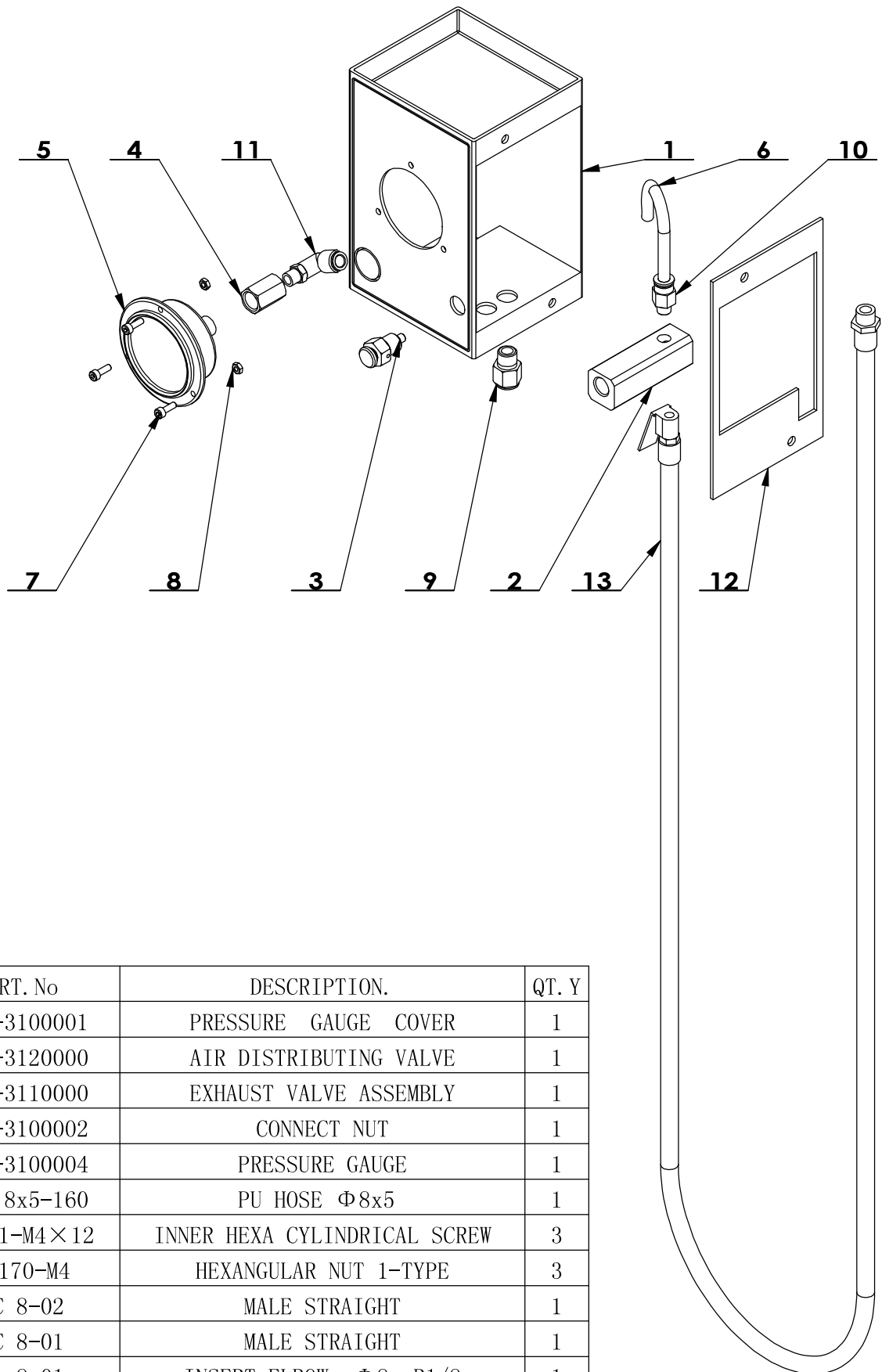

ITEM	PART. No	DESCRIPTION.	QT. Y
1	CT-K-3100001	PRESSURE GAUGE COVER	1
2	CT-K-3120000	AIR DISTRIBUTING VALVE	1
3	CT-K-3110000	EXHAUST VALVE ASSEMBLY	1
4	CT-K-3100002	CONNECT NUT	1
5	CT-K-3100004	PRESSURE GAUGE	1
6	PU $\Phi$ 8x5-160	PU HOSE $\Phi$ 8x5	1
7	GB70. 1-M4 $\times$ 12	INNER HEXA CYLINDRICAL SCREW	3
8	GB6170-M4	HEXANGULAR NUT 1-TYPE	3
9	FPC 8-02	MALE STRAIGHT	1
10	FPC 8-01	MALE STRAIGHT	1
11	FPL 8-01	INSERT ELBOW $\Phi$ 8, R1/8	1
12	CT-K-3100005	SIDE PANEL	1
13	CT-K-3100003	1.5m INFLATION HOSE	1

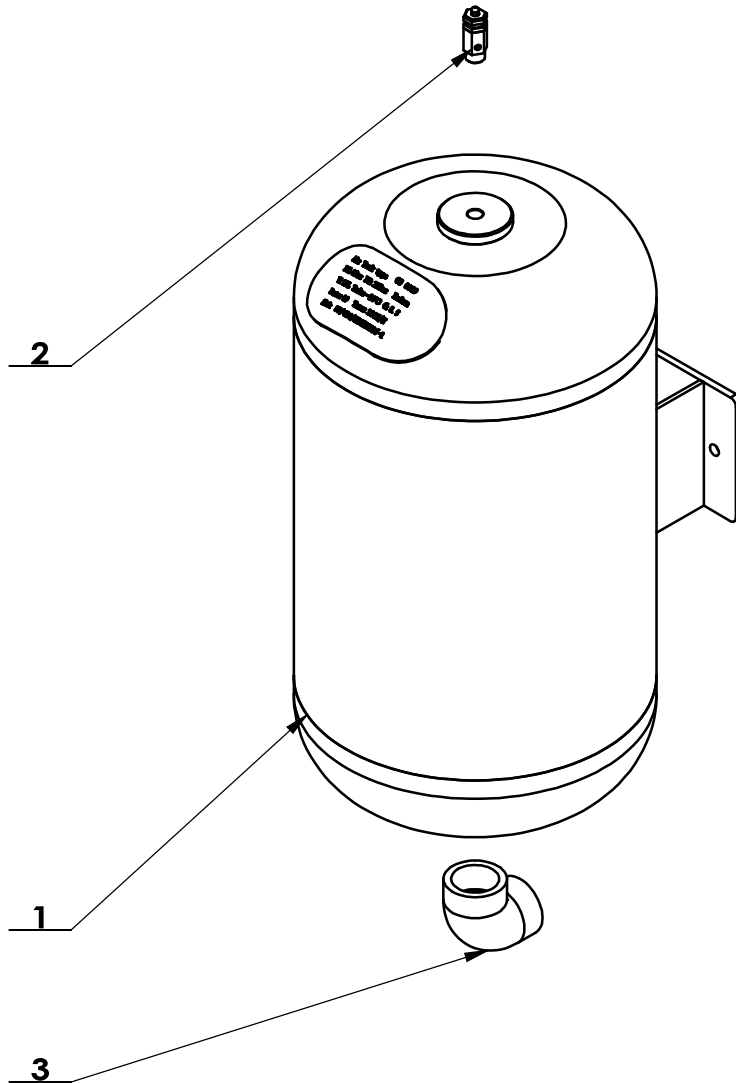

ITEM	PART. No	DESCRIPTION.	QT. Y
1	CT-K-4110000	AIR TANK	1
2	CT-K-4100001	SAFE VALVE	1
3	CT-K-4100002	ELBOW_90, G1"	1

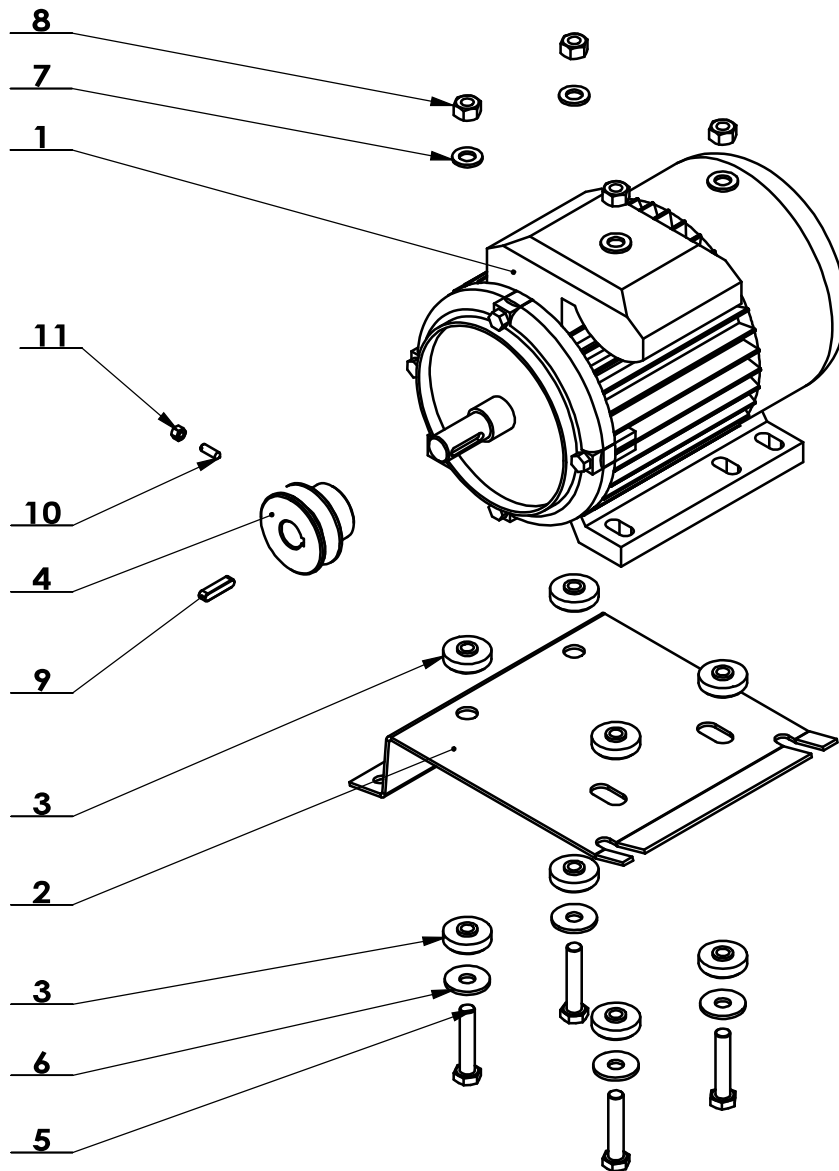

ITEM	PART. No	DESCRIPTION.	QT. Y
1	CT-DJ-0012112	MOTOR	1
2	CT-DJ-0000001	MOTOR SUPPORT	1
3	CT-DJ-0000002	RUBBER WASHER	8
4	CT-DJ-0000003	MOTOR BELT PULLEY	1
5	GB5781-M10×50	HEXANGULAR BOLT	4
6	GB96. 1-10	LARGE WASHER A GRADE	4
7	GB95-10	FLAT WASHER	4
8	GB41-M10	HEXANGULAR NUT	4
9	GB1096-6×6×28	COMMON FLAT KEY	1
10	GB71-M5×16	SLOTTED CONIC HEAD SET SCREW	1
11	GB41-M5	HEXANGULAR NUT	1

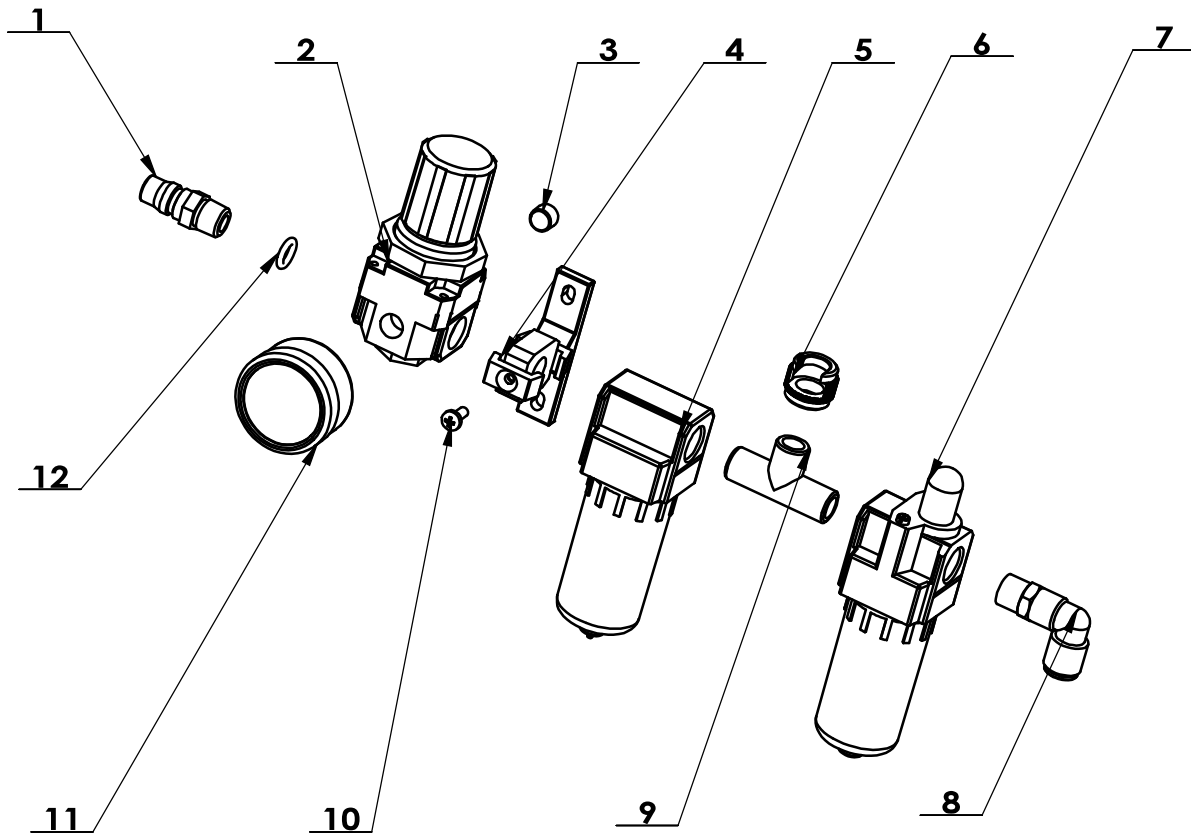

ITEM	PART. No	DESCRIPTION.	QT. Y
1	C-01-100000D	AIR SUPPLY CONNECTOR	1
2	H-40-1600001	PRESSURE ADJUST VALVE	1
3	FPS 01	PLUG MAIN BLOCK	1
4	CT-F-3000005	BRACKET	1
5	CT-F-3000001	WATER CUP	1
6	C-01-1500004	OPEN NUT	1
7	CT-F-3000002	OIL CUP	1
8	FPL 8-02	INSERT ELBOW $\Phi 8$ , R1/4	1
9	PEH 02-02	FAMALE UNION TEE	1
10	GB818-M4 $\times$ 10-H	CROSS PANHEAD SCREW	2
11	CT-F-3000004	PRESSURE GAUGE	1
12	GB3452.1-8 $\times$ 2.65-A	O-RING G TYPE	1

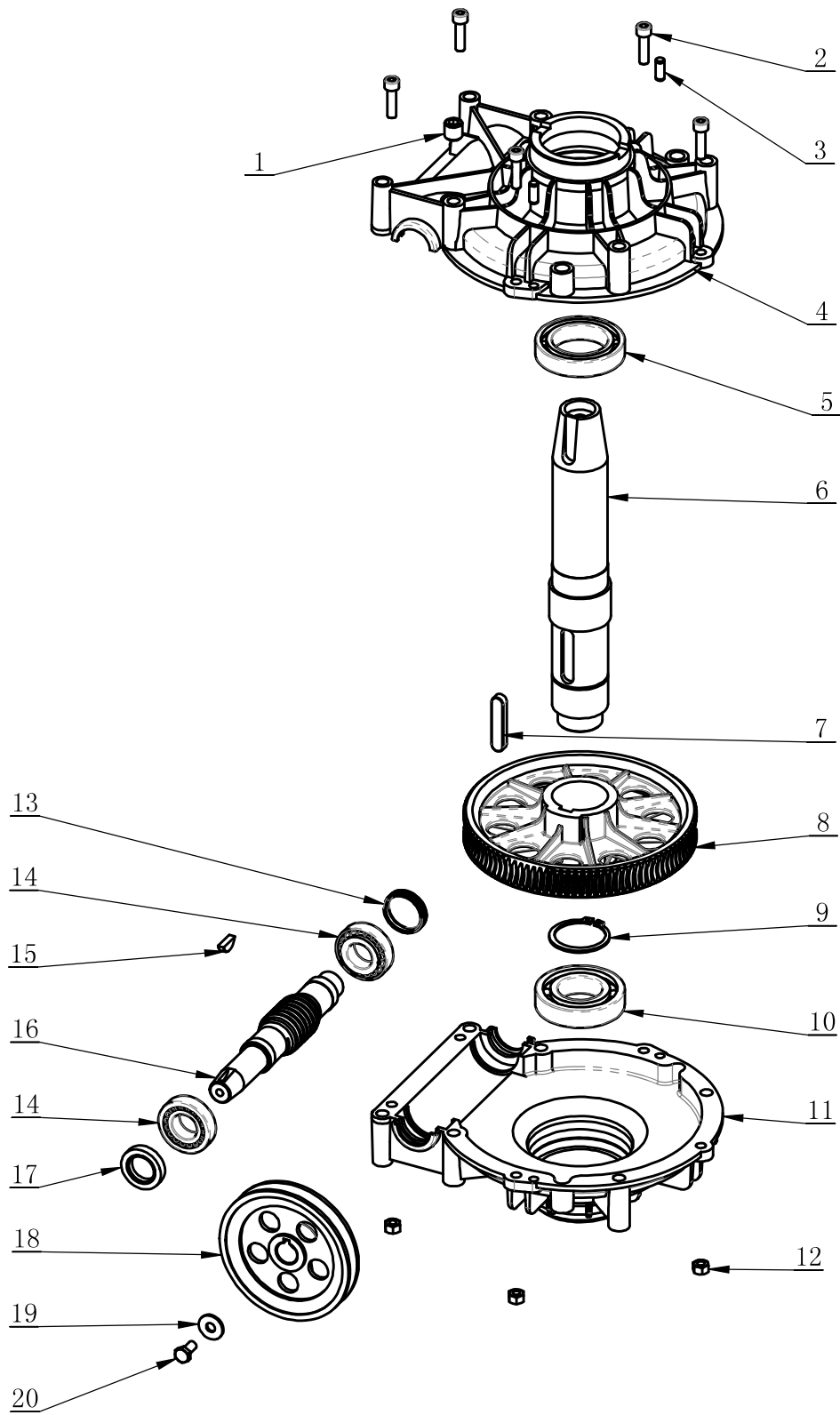

ITEM	PART. No	DESCRIPTION.	QT. Y
1	GB77-M16X1.5-16	SCREW	1
2	GB70.1-M8×30	INNER HEXA CYLINDRICAL SCREW	5
3	GB119.1-8×20	CYLINDRICAL PIN	2
4	CT-J-0000006	GEARBOX TOP	1
5	GB276-6010	DEEP GROOVE BALL BEARINGS	1
6	CT-J-0000001	WORM SHAFT	1
7	GB1096-12×8×56	COMMON FLAT KEY	1
8	CT-J-0000003	WORM	1
9	GB894.1-50	SHAFT ELATIC BIG RETAINING RING A-TYPE	1
10	GB276-6208	DEEP GROOVE BALL BEARINGS	1
11	CT-J-0000005	GEARBOX TOP	1
12	GB41-M8	HEXANGULAR NUT	5
13	CT-J-0100000	CAP	1
14	GB297-30205	CYLINDRICAL BALL BEARING	2
15	GB1099.1-6×9×22	COMMON SEMI-CIRCULAR KEY	1
16	CT-J-0000004	WORM ROD	1
17	FB25-40 GB13871.92	SEALED RING	1
18	CT-J-0000008	BELT PULLEY	1
19	GB96.2-8	LARGE WASHER C GRADE	1
20	GB5781-M8×16	HEXANGULAR BOLT	1





ITEM	PART. No	DESCRIPTION.	QT. Y
1	CT-LS-2000001	SHAFT-CLYNDR, 445	1
2	FPL 8-02	INSERT ELBOW $\Phi 8$ , R1/4	1
3	CT-LS-1000004	CYLINDER COVER	1
4	CT-LS-1000002	PISTON	1
5	CT-LS-1000003	CYLINDER BODY	1
6	FPL 8-01	INSERT ELBOW $\Phi 8$ , R1/8	1
7	GB6171- M18 $\times$ 1.5	NUT THIN TOOTH	1
8	GB/T 6177. 1-M6	HEXA FLANGE NUT	12
9	GB95-6	FLAT WASHER	12
10	GB70. 1-M6 $\times$ 20	INNER HEXA CYLINDRICAL SCREW	12
11	GB893. 2-30	ELASTIC RETAINING RING B-TYPE	1
12	CT-LS-1100000	CYCLINDER SEALING PARTS ASSEMBLY	1
12. 1	CT-LS-1000007	CLAMP RING	2
12. 2	CT-LS-1000008	PISTION SUPPORT RING	1
12. 3	CT-LS-1000011	Y-RING	2
12. 4	GB3452. 1-185 $\times$ 3. 55-G	O-RING G TYPE	1
12. 5	CT-LS-1000009	GUIDER SPACER	1
12. 6	CT-Y-0160007	DUSTPROOF SEALING RING	1

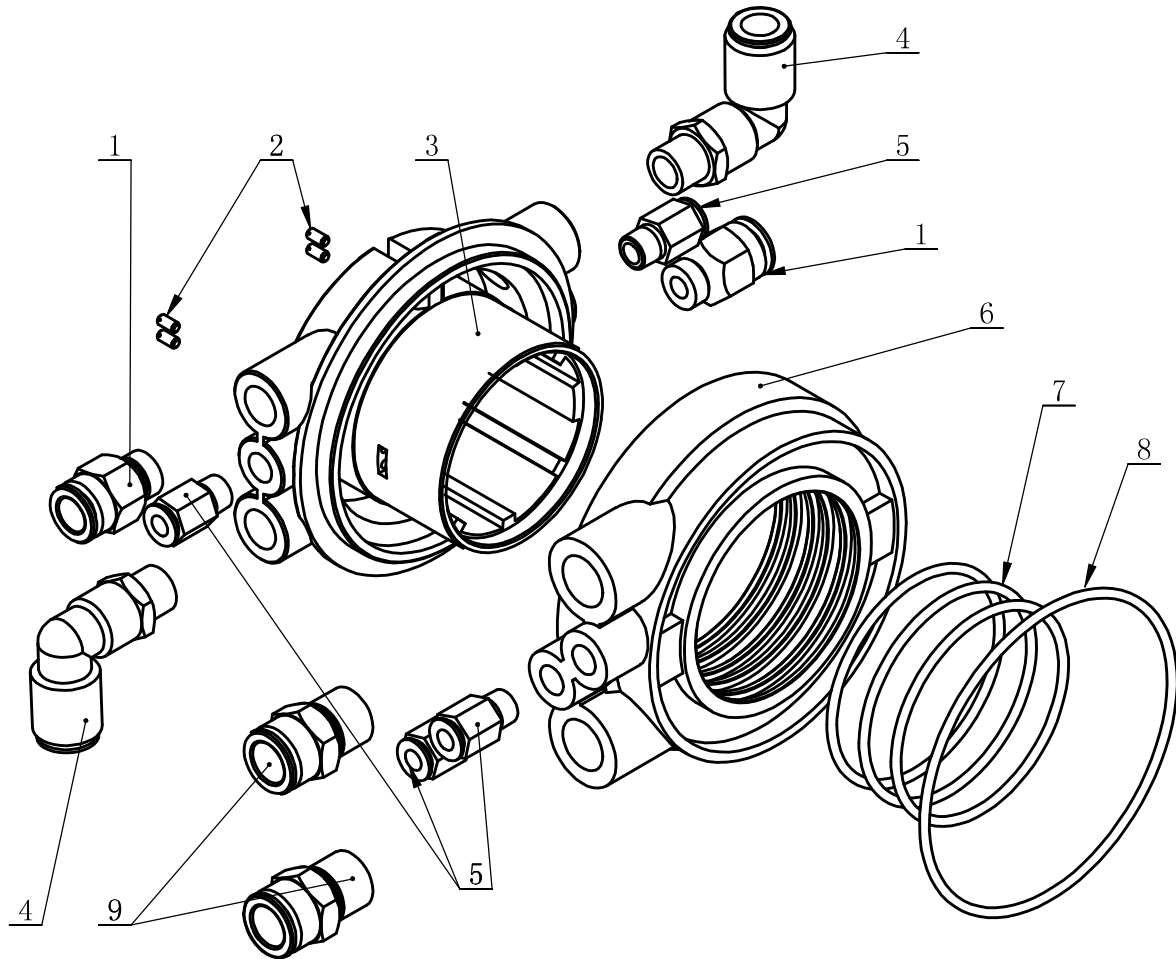

ITEM	PART. No	DESCRIPTION.	QT. Y
1	FPC 10-02	MALE STRAIGHT	2
2	GB73-M3×6	SLOTTED FLATTEN HEAD SET SCREW	4
3	CT-Q-2000001	AIR GUIDE ROTATION BUSHING	1
4	FPL 10-02	MALE ELBOW	2
5	FPC 6-01	MALE STRAIGHT	4
6	CT-Q-2000002	AIR GUIDE EXTERNAL BUSHING	1
7	GB3452. 1-60×2. 65-G	hydraulic-pneumatic rubber o-ring A type	3
8	GB3452. 1-90×2. 65-G	O-RING 90X2.65	1
9	FPC 12-03	MALE STRAIGHT	2
10	T-J. 00. 03	AIR GUIDE EXTERNAL BUSHING	-

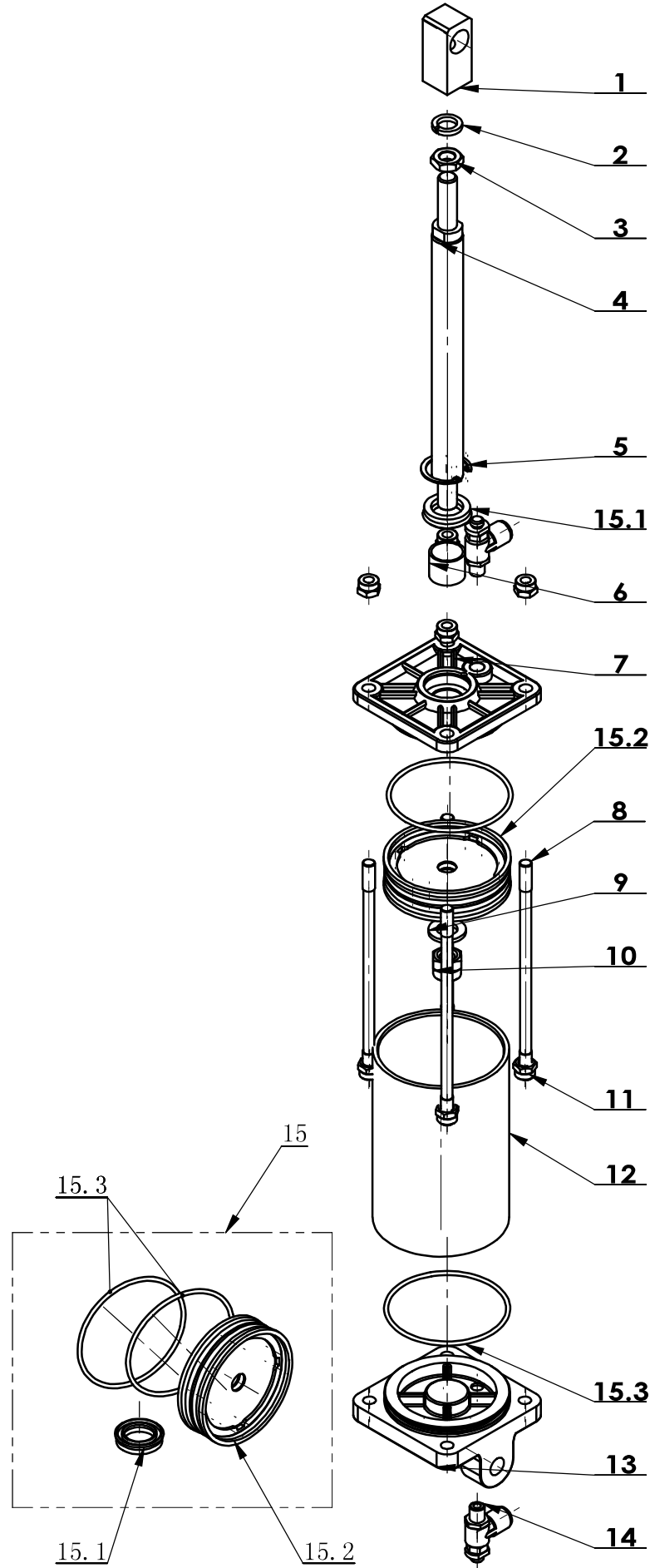

ITEM	PAET. NO	DESCRIPTION	QT. Y
1	CT-XD-1000004	SHAFT CONNECTOR	1
2	GB93-12	STANDARD SPRING WASHER	1
3	GB/T6172. 1-M12	HEXANGULAR THIN NUT	1
4	CT-XD-2000002	PISTON ROD	1
5	GB893. 1-30	ELASTIC RETAINING RING A-TYPE	1
6	JH1 2020	BEARING-SLIDE	1
7	CT-Y-6600001	CYLINDER FRONT COVER	1
8	CT-XD-1000003	BARS	4
9	GB95-12	FLAT WASHER	1
10	GB889. 1-M12	1-TYPE PREVAILING TORQUE TYPE HEXAGON LOCK NUT	1
11	GB889. 1-M8	1-TYPE PREVAILING TORQUE TYPE HEXAGON LOCK NUT	8
12	CT-XD-1000001	CYLINDER BODY	1
13	CT-XD-1000005	CYLINDER REAR COVER	1
14	FJSC 8-01	ELBOW SPEED CONTROLLER	2
15	CT-XD-2100000	O-RINGS ASSEMBLY	1
15.2	CT-Y-6610000	PISTON	1
15.1	CT-Y-0160007	SEAL-ROD, CYLNDR	1
15.3	GB3452. 1-75×2. 65-G	HYDRAULIC-PNEUMATIC RUBBER O- RING G TYPE	2

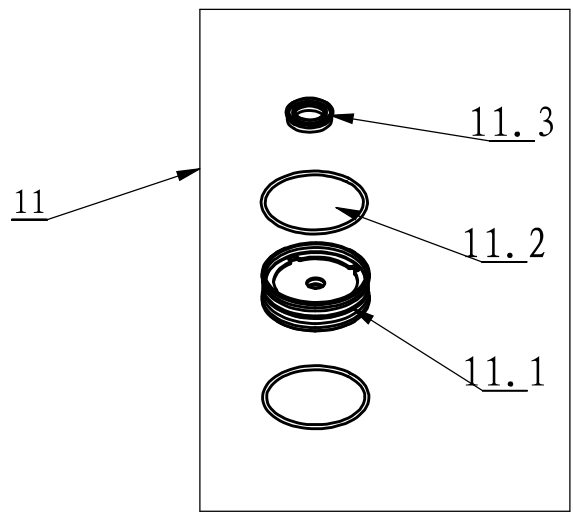
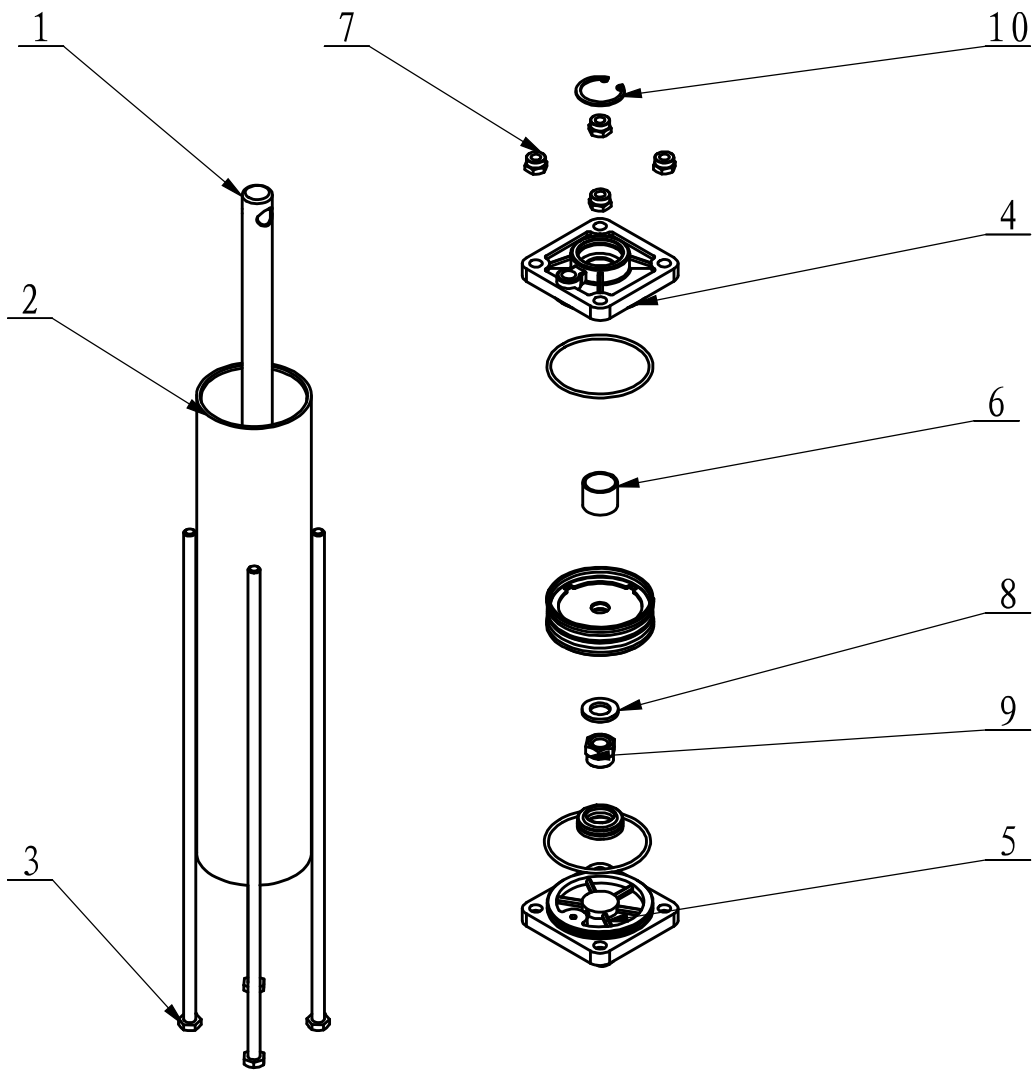

ITEM	PART. No	DESCRIPTION.	QT. Y
1	CT-Y-1120001	SHAFT-CYLNR	1
2	CT-Y-1120002	SLEEVE-CYLNR 70	1
3	CT-Y-1120003	BOLT	4
4	CT-Y-0160002	FRONT COVER	1
5	CT-Y-0160003	REAR COVER	1
6	JH1 2020	BEARING-SLIDE	1
7	GB889. 1-M8	1-TYPE PREVAILING TORQUE TYPE HEXAGON LOCK NUT	4
8	GB95-12	FLAT WASHER	1
9	GB889. 1-M12	1-TYPE PREVAILING TORQUE TYPE HEXAGON LOCK NUT	1
10	GB893. 1-30	ELASTIC RETAINING RING A-TYPE	1
11	CT-Y-1121000	CYLINDER SEALING PARTS ASSEMBLY	1
11.1	CT-Y-0160007	SEAL-ROD, CYLNR	1
11.2	CT-Y-0161000	PISTON-W/WSHR, ASSY	1
11.3	GB3452. 1-65×2. 65-G	HYDRAULIC-PNEUMATIC RUBBER O-RING G TYPE	2

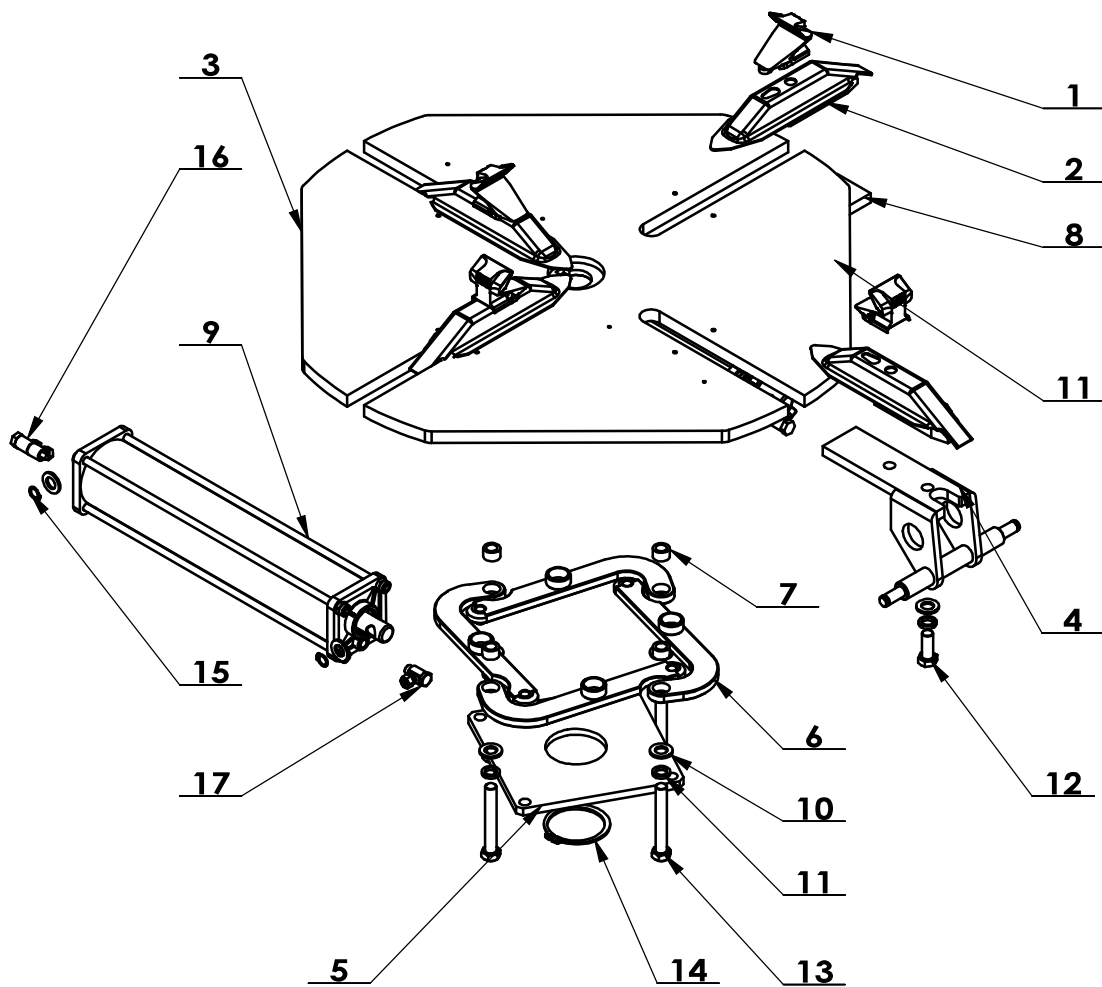

ITEM	PART. No	DESCRIPTION.	QTY
1	CT-Y-1110000	SLIDE COVER	4
2	CT-Y-0100002	CLAMP	4
3	CT-Y-2110000	TURNTABLE	1
4	CT-Y-2140000	BRACKET-CYLINDER	2
5	CT-Y-0150000	SQUARE TURNTABLE	1
6	CT-Y-2120000	CONNECTION PLATE	4
7	CT-Y-0100003	SPACER	4
8	CT-Y-1100001	PRESS BOARD	2
9	CT-Y-1120000	CYLINDER ASSEMBLY	2
10	GB95-12	FLAT WASHER	12
11	GB93-12	STANDARD SPRING WASHER	8
12	GB5781-M12×30	HEXANGULAR BOLT	4
13	GB5780 M12X83	HEXANGULAR BOLT	4
14	GB894. 1-65	SHAFT ELATIC BIG RETAINING RING A-TYPE	1
15	GB894. 1-12	SHAFT ELATIC BIG RETAINING RING A-TYPE	4
16	CT-Y-0100005	HINGE TEE $\Phi 6 R1/8''$	2
17	CT-Y-0100006	HINGE ELBOW $\Phi 6 R1/8''$	2

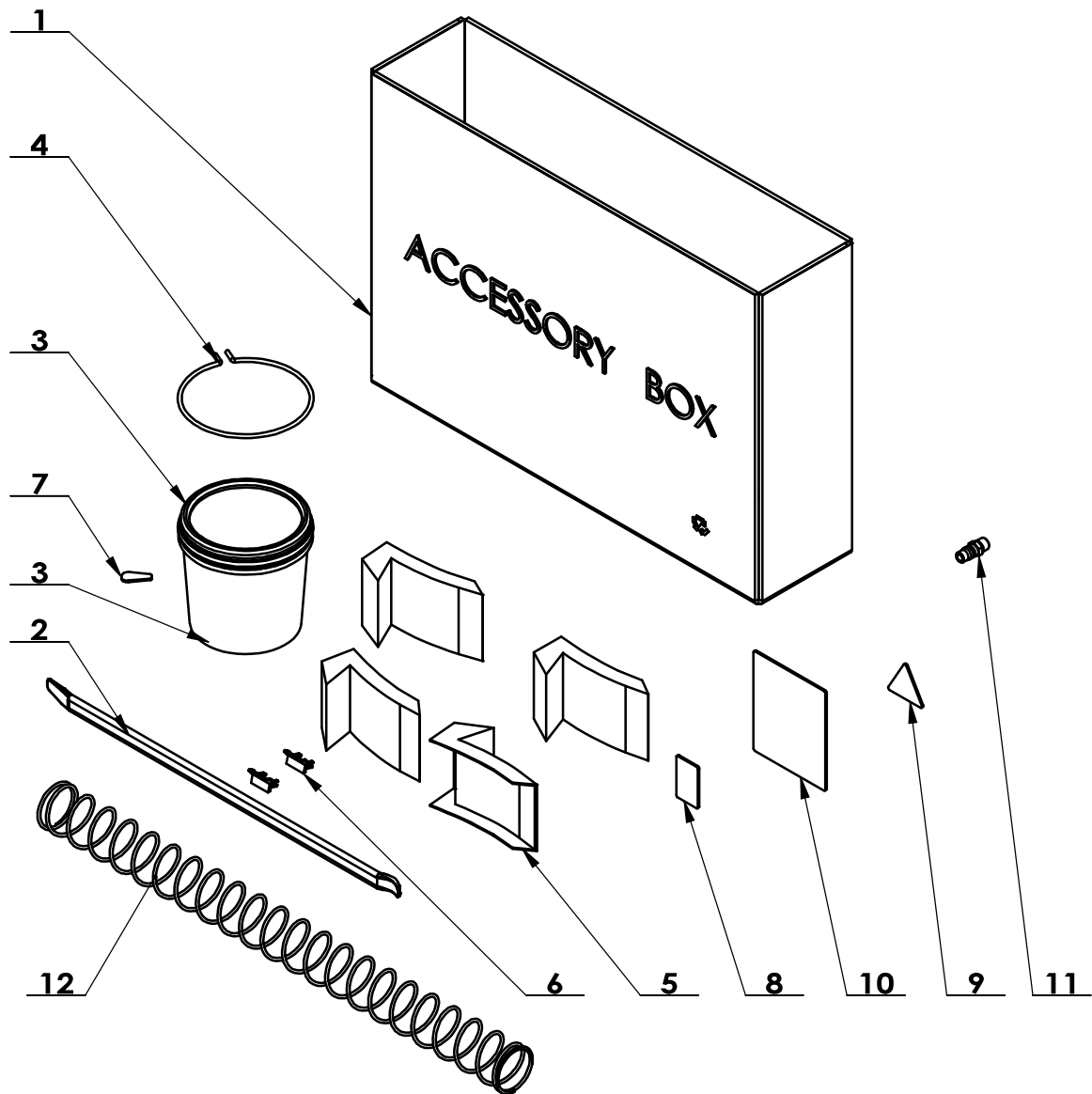

ITEM	PART. No	DESCRIPTION.	QT. Y
1	C-01-8000001	ACCESSORY BOX	1
2	C-01-1000008	CROWBAR 20 "	1
3	C-01-1300000	GREASE CONTAINER	1
4	C-01-1000005	BRACKET	1
5	C-01-8000002	CLAMP PROTECTION COVER	4
6	C-31-1300014	SHEATH	2
7	C-31-1300015	PLASTIC COVER	1
8	C-31-8000003	GUARANTEE	1
9	C-31-8000002	PASS CARD	1
10	C-31-8000001	USER MANUAL	1
11	C-01-100000D	AIR SUPPLY CONNECTOR	1
12	C-70-1220001	VERTICAL SHAFT SPRING	1